

...TI theory applies

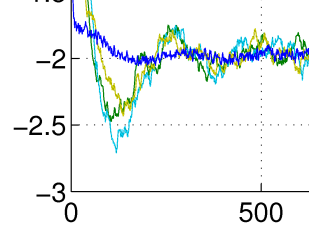

Tracking resilient

Distributed Solution of Optimal Power Flow

Distributed computation structure

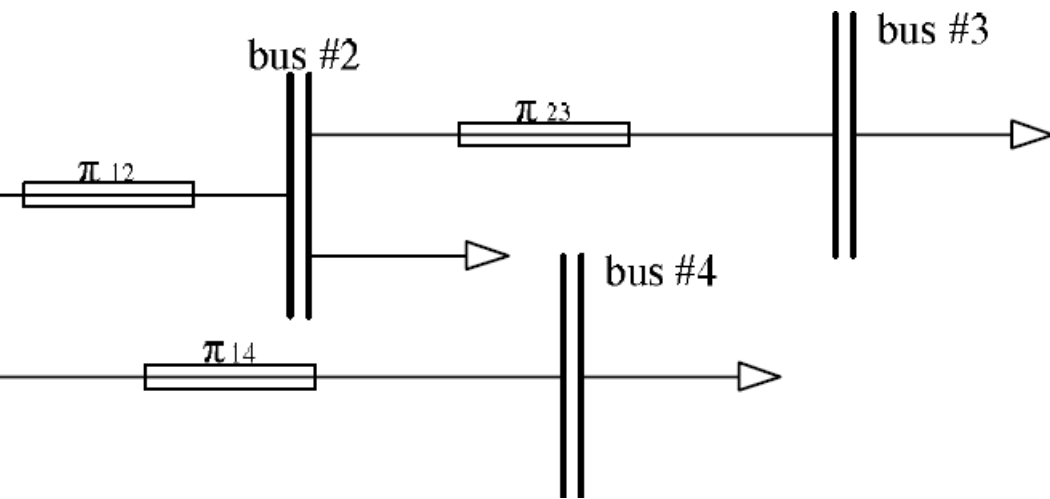

When will a

SDP zero
duality gap

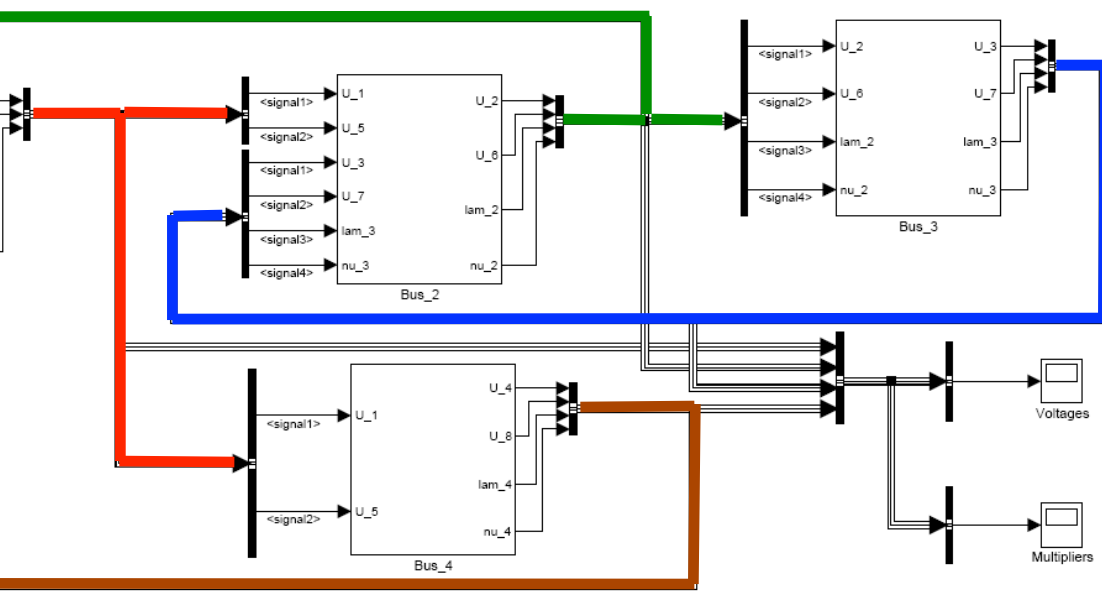

• The app

When does

• Suppose

with B^*