META-II TECHNICAL AREA TWO: METRIC OF ADAPTABILITY FOR CYBER-PHYSICAL SYSTEMS

Donna H. Rhodes and Adam M. Ross

Massachusetts Institute of Technology

**SEPTEMBER 2011
Final Report**

TABLE OF CONTENTS

Section	Page
TABLE OF CONTENTS	iii
List of Figures	v
List of Tables	vi
1. SUMMARY	7
1.1 Research Subject	7
1.2 Performing Organization	7
1.3 Problem	7
1.4 Results	7
1.4.1 Publications	8
1.4.2 Valuation Approach for Strategic Changeability (VASC)	8
1.4.3 Adaptability Metrics	8
1.4.4 Considerations for Deployment	9
1.4.5 Documented Case Applications	9
1.4.6 Conclusions	9
2. INTRODUCTION	11
3. METHODS, ASSUMPTIONS and PROCEDURES	14
3.1 Methods and Assumptions	14
3.1.1 Change Events as Paths	14
3.1.2 Changeability Taxonomy Based on Change Pathway	16
3.1.3 Epoch-Era Analysis	16
3.1.4 Tradespace Networks	17
3.1.5 Filtered Outdegree	18
3.1.6 Real Options Analysis for Valuing Changeability	19
3.2 Procedures	20
3.2.1 Assumption: Characteristics of Data Sets	21
4. RESULTS AND DISCUSSION	23
4.1 Results	23
4.1.1 Framing Concepts Leveraged from Prior Work	23
4.1.1.1 Change “Rules” and Mechanisms	23
4.1.1.2 “Degree of” Change	23
4.1.1.3 Addressing “Counting” and “Magnitude” Value	26
4.1.1.4 Using Strategies for Short Run and Long Run Valuations	26
4.1.2 Development of Metrics	27
4.1.2.1 Necessity of Multiple Metrics for Changeability	28
4.1.2.2 Empirical Metrics Comparison	28
4.1.2.3 Evaluating Potential Changeability Metrics	29
4.1.3 Valuation Approach for Strategic Changeability (VASC)	32
4.1.3.1 Set Up Data for Epoch-Era Analysis	32
4.1.3.2 Identify Designs of Interest	32
4.1.3.3 Define Rule Usage Strategies	32
4.1.3.4 Conduct Multi-Epoch Changeability Analysis	33

4.1.3.5	Conduct Era simulation and Analysis.....	33
4.1.3.6	Metrics Usage in VASC.....	33
4.1.4	Case Applications	33
4.1.4.1	X-TOS Case Study.....	34
4.1.4.2	Space Tug Case Study	49
4.1.4.3	Satellite Radar Case Study.....	58
4.1.5	Publications.....	59
4.2	Discussion.....	60
4.2.1	Fit of Research Outcomes with Larger META Projects.....	60
4.2.2	Scalability of Approach	61
4.2.2.1	Programming Challenges Uncovered in SRS Case Study.....	61
4.2.3	Incorporating into Existing Studies	62
4.2.4	Change Mechanisms Elaborated.....	63
4.2.5	Considerations for Implementation.....	64
4.2.6	Future Research	65
5.	CONCLUSIONS.....	67
5.1	Research Contributions.....	68
6.	REFERENCES	69
	APPENDIX A – Publications and Presentations	71
	LIST OF SYMBOLS, ABBREVIATIONS, AND ACRONYMS.....	72
	GLOSSARY OF TERMINOLOGY	73

List of Figures

Figure	Page
1. Change Defined as State Transition	14
2. System Changes Depicted using Agents, Mechanisms, and Effects	15
3. Change Pathway with Perturbation-Agent-Mechanism-State Change	15
4. System Needs versus Expectations across Epochs of the System Era	16
5. Tradespace Transformed into a Tradespace Network through Transition Rules	18
6. Path Counting including Agent-Mechanism Paths	18
7. (left) Outdegree; (right) Filtered Outdegree	19
8. Example of Design Variables and Attributes for each Design Considered	21
9. Illustration of Epochs Showing Variation in Contexts and Needs	22
10. Degree of Changeability as a Function of Number of Mechanisms and End States	23
11. Justification for Need to Account for Number of Change Paths	24
12. “Best” Path Selection Determined by Rule Execution Strategy	25
13. Tradespace Network Simplification via Strategy	26
14. Epoch and Era Strategies Determine Value of Changeability	27
15. Attractiveness of Change Rules by Strategy across an Era	27
16. Conflicting Dimensions of Aspects to Account for Valuable Changeability	28
17. X-TOS - Design Space NPT	37
18. X-TOS - Design Space fNPT	38
19. X-TOS - Design Space FOD for Two Thresholds	39
20. X-TOS - Maximize Utility FPS Distribution	42
21. X-TOS - Maximize Efficiency FPS Distribution	44
22. X-TOS - Removal Weakness (FPS Impact of Removing “Redesign”)	47
23. Space Tug Multi-arc Transition Matrix	51
24. Space Tug Designs with High NPT	52
25. Space Tug Designs with High fNPT	52
26. Space Tug Designs with High FOD	53
27. Space Tug efNPT by Strategy for Designs of Interest	54
28. Space Tug FPS Distribution for Maximize Utility Strategy	55
29. Space Tug FPS Distribution for Maximize Efficiency Strategy	56
30. Space Tug FPS Distribution for Survive Strategy	56
31. Space Tug ARI Comparison across Change Rules	57
32. Space Tug Design E Rule Usage by Strategy across a 10 Year Era	58
33. META Design Flow with Changeability Metrics Indicated	60
34. Change Mechanisms as Part of Change Options	63
35. Human vs. Automation in Approach	65
36. Delay in Experienced Utility as a Function of Change Mechanism-Lifecycle Phase	66
37. Data Flow for VASC Metrics	67

List of Tables

Table	Page
1. Agents, Mechanisms, Effects, and Paths Shown in Figure 2.....	15
2. Comparison of Metrics Studied in Investigation	29
3. Potential Valuable Changeability Metrics Evaluated by Criteria.....	31
4. Final Set of Valuable Changeability Metrics.....	31
5. Metrics with Relation to Changeability Aspects and VASC Step.....	33
6. X-TOS Case Design and Value Attributes	34
7. X-TOS Rules (Change Mechanisms).....	36
8. X-TOS Case Study Designs of Interest	40
9. X-TOS - NPT and eNPT.....	41
10. X-TOS - 1% fNPT and efNPT.....	41
11. X-TOS - Maximize Utility FPS Statistics.....	42
12. X-TOS - Maximize Efficiency FPS Statistics	44
13. X-TOS – Era Analysis Results	46
14. X-TOS - Change Mechanism Usage Likelihood (Random Epoch Switch)	47
15. X-TOS - Era Statistics (Redesign Removed).....	48
16. Space Tug Study Transition Rules (Change Mechanisms).....	50
17. Space Tug Designs of Interest	53
18. Space Tug Changeability Lifecycle Cost/Benefit Tradeoff.....	58
19. Scalability of Activities in VASC.....	61
20. Examples of Systems, Path Enablers, and Change Mechanism	64
21. Additional Example Change Mechanisms.....	64
22. Final Set of Valuable Changeability Metrics.....	68

1. SUMMARY

The DARPA META-II program goal is to substantially improve the design, manufacturing, and verification of complex cyber-physical systems, and particularly defense and aerospace systems such as ground combat vehicles, airplanes, and rotorcraft. The program is motivated by the accelerating complexity of systems. DARPA META program manager Mr. Paul Eremenko describes the goal as: “to rethink how we design and build systems” (Warwick, 2010).

1.1 Research Subject

The subject of this research effort addresses one of the specific METAII objectives, a metric for adaptability. DARPA defines adaptability, in context of this program, as *the ability of a system to change easily, quickly, and inexpensively (i.e., with minimum incurrence of cost and degradation in performance) in response to a wide spectrum of anticipated and unanticipated perturbation events exogenous or endogenous to the system.*

1.2 Performing Organization

The research has been performed by the Massachusetts Institute of Technology (MIT) Systems Engineering Advancement Research Initiative (SEARI), a research group affiliated with MIT’s Engineering Systems Division (ESD) and the Center for Technology, Policy and Industrial Development (CTPID). The research leveraged MIT SEARI’s prior and ongoing research, and its existing infrastructure to support the effort. The SEARI research group mission is *to advance the theories, methods, and the effective practice of systems engineering applied to complex socio-technical systems through collaborative research.* The MIT principal investigator was Dr. Donna H. Rhodes, and the MIT co-principal investigator was Dr. Adam M. Ross. MIT Professor Daniel E. Hastings was involved in a strategic guidance role. A number of graduate and undergraduate students worked on the project.

1.3 Problem

Success in modern systems is strongly determined by being able to respond to perturbations on appropriate timescales. Current metrics for assessing the DARPA adaptability of a system suffer from data accessibility bias. In particular, the costs for embedding system change options, as well as executing these change options, are much better characterized than the benefits of doing so. This imbalance is partly due to prevailing valuation techniques requiring the probabilities of outcomes driving the execution of real options, as well as the specific “destination” end states for a system. The benefit of more “open-ended” change options is therefore undervalued in analysis. Likewise, from an acquisition perspective, the cost of embedding options is typically incurred up-front in the lifecycle while the benefit may occur in some uncertain future. The ability to pursue active value robust strategies (adaptability, or more generally changeability) must be properly valued in order to be proactively embedded in a system architecture. As such, addressing the cost-benefit imbalance is essential. Useful metrics are needed to inform the selection of promising adaptable concept designs for further analysis.

1.4 Results

The research effort sought to develop a metric of adaptability, but what was discovered is that several important dimensions are in tension when attempting to account for valuable

adaptability, or more generally, changeability. These dimensions in tension include: design versus performance considerations, short run versus long run returns, and context specific or general applicability of the metrics. As a result of this finding, a set of metrics was developed, along with a valuation approach in order to provide guidance in calculation and use of these metrics to design data sets.

1.4.1 Publications

During the performance of the contract, one conference publication was published and presented at the 9th Conference on Systems Engineering Research during April 2011 in Los Angeles, CA. The paper "A Method Using Epoch-Era Analysis to Identify Valuable Changeability in System Design," and was authored Matthew Fitzgerald, Adam Ross, and Donna Rhodes. The paper is available in the proceedings and on the MIT SEArI website (<http://seari.mit.edu>). The research team expects to publish two additional papers in 2012. In addition, an MIT masters thesis related to the project will be forthcoming in May 2012 by graduate student Matthew Fitzgerald, and following publication will be posted on the SEArI website.

1.4.2 Valuation Approach for Strategic Changeability (VASC)

The synthetic approach to valuating changeability across the set of metrics developed in this research consists of five steps:

- Step 1: Set up data for epoch-era analysis
- Step 2: Identify designs of interest
- Step 3: Define rule usage strategies
- Step 4: Conduct multi-epoch changeability analysis
- Step 5: Conduct era simulation and analysis

1.4.3 Adaptability Metrics

A set of adaptability metrics was developed and is summarized below:

Aspect of Valuable Changeability	Acronym	Stands For	Definition
Robustness via "no change"	NPT	Normalized Pareto Trace	% epochs for which design is Pareto efficient in utility/cost
Robustness via "no change"	fNPT	Fuzzy Normalized Pareto Trace	Above, with margin from Pareto front allowed
Robustness via "change"	eNPT, efNPT	Effective (Fuzzy) Normalized Pareto Trace	Above, considering the design's end state after transitioning
"Value" gap	FPN	Fuzzy Pareto Number	% margin needed to include design in the fuzzy Pareto front
"Value" of a change	FPS	Fuzzy Pareto Shift	Difference in FPN before and after transition

Aspect of Valuable Changeability	Acronym	Stands For	Definition
“Value” of a change	ARI	Available Rank Increase	# of designs able to be passed in utility via best possible change
Degree of changeability	OD	Outdegree	# outgoing transition arcs from a design
Degree of changeability	FOD	Filtered Outdegree	Above, considering only arcs below a chosen cost threshold

1.4.4 Considerations for Deployment

The approach and set of metrics developed in this research is generally applicable to design decision problems where there is a need to account for the cost and benefit of investing in and executing changes in designs. Most of the work is targeted toward analysis and decision making during conceptual design, with low fidelity models to evaluate alternatives, however, the approach is applicable throughout the lifecycle to any level of abstraction in the system. The key consideration when applying the approach later in the lifecycle, is the concomitant increase in computational expense for evaluating alternatives with higher and higher fidelity models, simulations, and tests. In order to manage this increase in evaluation cost, one must reduce the breadth of alternatives considered, as well as take advantage of improvements in algorithm design (to improve the scaling properties of the suggested approach) and parallelization (to improve raw computing time for generating results). The approach was specifically developed in order to maximize potential for parallelization, as well as to focus human-intervention only at the beginning and end of the process, maximizing the ability to leverage automation.

1.4.5 Documented Case Applications

The research has resulted in three documented case examples: X-TOS, Space Tug, and Satellite Radar System. The primary purpose of the application of the X-TOS case in this research investigation was twofold: (1) to serve as an experimentation case to develop the metrics assessment approach, and (2) to test the various adaptability metrics identified through empirical investigation. The primary purpose of the application of the Space Tug case in this research investigation was to demonstrate the end-to-end process in a relatively simple case. In particular, the application to the Space Tug system demonstrates both evaluation of valuable changeability within epochs (short run value of changeability) as well as across eras via “strategies” (long run value of changeability). The primary purpose of the application of the Satellite Radar System case in this research investigation was to demonstrate scalability of the end-to-end process in a more complex case. The cases are detailed in Section 4 of this report.

1.4.6 Conclusions

The research conducted has developed a set of metric for valuating adaptability in a more complete manner than existed in the literature to this point. Some challenges with scalability to large numbers of design alternatives or long computation times remain, but are not expected to be insurmountable. A key benefit that emerged from the development of VASC and its related

metrics, is the ability to not only quantify the costs and benefits of investing in changeability, but also a more holistic ability to consider the driving strategic need for changeability, providing focus on the most salient aspects of the problem. Adaptability is desired because of a need to be able to alter a system in response to a perturbation, whether that perturbation occurs early or late in the lifecycle. VASC provides a means to consider that spectrum of perturbations and empowers analysts with the tools to determine and justify investment in system changeability to most effectively and efficiently overcome those perturbations.

2. INTRODUCTION

The DARPA META-II program goal is to substantially improve the design, manufacturing, and verification of complex cyber-physical systems, and particularly defense and aerospace systems such as ground combat vehicles, airplanes, and rotorcraft. The program is motivated by the accelerating complexity of systems. DARPA META program manager Mr. Paul Eremenko describes the goal as: “to rethink how we design and build systems”.**Error! Bookmark not defined.**

The subject of this research effort addresses one of the specific META-II objectives, a metric for adaptability. DARPA defines adaptability, in context of this program, as *the ability of a system to change easily, quickly, and inexpensively (i.e., with minimum incurrence of cost and degradation in performance) in response to a wide spectrum of anticipated and unanticipated perturbation events exogenous or endogenous to the system.*

The research has been performed by the MIT SEArI, a research group affiliated with MIT’s ESD and the CTPID. The research leveraged MIT SEArI’s prior and ongoing research, and its existing infrastructure to support the effort. The SEArI research group mission is *to advance the theories, methods, and the effective practice of systems engineering applied to complex socio-technical systems through collaborative research.* The MIT principal investigator was Dr. Donna H. Rhodes, and the MIT co-principal investigator was Dr. Adam M. Ross. MIT Professor Daniel E. Hastings was involved in a strategic guidance role. A number of graduate and undergraduate students worked on the project.

This technical report provides a comprehensive description of the one year research effort. Section 1 provides an executive summary. In this introductory Section 2 we describe the problem, scope of the work, background information, targeted impact, and innovations. In Section 3 we discuss the methods, assumptions, and procedures. This section includes the constructs, methods, and data sets that have resulted from prior research that were used as a foundation for this work. Section 4 includes the specific results of the research, and a discussion on several topics: the fit with larger META projects, scalability, incorporating into existing studies, limitations/gaps, and future research. The overall conclusions are discussed in Section 5.

Problem Description. Current metrics for assessing the DARPA *adaptability*¹ of a system suffer from data accessibility bias. In particular, the costs for embedding system change options, as well as executing these change options, are much better characterized than the benefits of doing so. This imbalance is partly due to prevailing valuation techniques requiring the probabilities of outcomes driving the execution of real options, as well as the specific “destination” end states for a system. The benefit of more “open-ended” change options is therefore undervalued in analysis. Likewise, from an acquisition perspective, the cost of embedding options is typically incurred up-front in the lifecycle while the benefit may occur in some uncertain future. The ability to pursue active value robust strategies (adaptability, or more generally changeability) must be properly valued in order to be proactively embedded in a system architecture. As such, addressing the cost-benefit imbalance is a necessary next step.

¹ **IMPORTANT NOTE:** The DARPA term “adaptability” is equivalent to the MIT SEArI term “changeability” which encompasses adaptability (endogenous change agent) and flexibility (exogenous change agent). In this report we will use the term changeability as synonymous with DARPA adaptability.

Scope and Research Goals. The overall research objective was to develop a comprehensive quantitative *metric for adaptability* that can be traded against other system metrics. Previous MIT research has developed a rigorous definition and metrics for changeability (such as “filtered outdegree” in Ross, 2006). This research has built on prior foundational work by generalizing the formulation of the adaptability metric, allowing for independence of enumeration of end states and dependence on specification of change mechanisms, whose omission from previous metrics has resulted in the undervaluation of adaptability in systems architectures.

Targeted Impact. Once properly characterized with appropriate benefits, as well as costs, it is anticipated that more system acquirers will recognize the value of making up-front investments in options that allow for system changeability at appropriate points in time over a system’s lifecycle. The inclusion of active value robustness strategies will result in both long run program cost savings, as well as sustainment of system value delivery across both endogenous and exogenous perturbations.

Key Innovations. This research has several key innovations that have not been adequately addressed in other methods, techniques, and research. These innovations include a rigorous mathematical generalization of a “degree of adaptability” metric, identification of architecture features that correlate with adaptability, and creation of an ability to more fully account for benefits of adaptability, allowing for justification of investment in adaptability-enabling or enhancing system features.

The modern system development and acquisition environment involves a number of dynamic factors including changing technologies, user sets, concept of operations, and threats. The long duration and complex nature of system development efforts often results in the need to fix requirements, including needs, concepts, and technologies, many years prior to actual system operation. A common approach to dealing with the inevitable change facing a system is to encapsulate the future as fraught with uncertainty. Techniques exist for dealing with uncertainty, including the concept of real options. Early system architecting and development, when the significant costs and capabilities of the system are scoped and specified, is a key leverage point for making high impact decisions that will strongly affect the ultimate lifecycle success of the system. Unfortunately analyses to support this critical decision are strongly biased by the difficulty of quantification for the costs and benefits of embedding flexibility into a system architecture. Often the costs of adaptability are more easily accessible and quantifiable, due to over-representation in the near term, and are not offset by benefits accrued in the long term. This work has addressed the need to more fully account for all of the costs and benefits on a common basis, even if they cannot be quantified in terms of dollars.

Developing a positive response to uncertainty and change requires *changeability* (Fricke and Schulz, 2005; McManus and Hastings, 2006). MIT has made significant progress toward an architecting science in recent years, including an enriched definition of and metrics for changeability. Prior changeability quantification work tended to be more heuristic-driven (Fricke et al., 2000; Fricke and Schulz, 2005), however, MIT has introduced theoretically-derived quantifications that remove the bias inherent in heuristics (Ross et al., 2008). Current methods to quantify ‘flexibility and adaptability’, as subtypes of changeability, tend to be empirically derived and therefore are contextually biased (Chen and Yuan, 1998; Rajan et al., 2005; Keese et al., 2007). This metric requires a quantification of whether a system can change itself or be changed (in response to perturbations), as well as the value (benefit net cost and time) of executing the change.

Upfront critical decision regarding whether and where to embed adaptability requires not only the ability to quantify adaptability, but also the ability to *value* adaptability. Prior valuation work, while useful in certain instances, is too assumption-limited or is mathematically inaccessible (Nilchiani and Hastings, 2007), limiting its usefulness as a practical method. The results of classical real options analysis may suffer from lack of support from senior decision makers due to esoteric or unreasonable assumptions (Shah et al., 2008). To develop a decision maker useful adaptability valuation analysis method, this research aimed to develop the ability to value adaptability in a more rigorous manner, incorporating a theoretically derived, yet accessible, quantification of adaptability.

The research effort included three interrelated tasks. The first was the quantification of degrees of adaptability across the spatial-temporal system architecture, extending beyond the prior MIT work on “filtered outdegree” of countable mechanisms, specified end states. The task aimed to develop a mathematical treatment of quantifying adaptability change paths as related to the number of mechanisms and number of end states.

The second task was the identification of architectural features that drive an adaptability metric. This task developed architectural approaches and strategies for generating these types of change paths as a function of time-space location within a system architecture. The existing literature, as well as insights from recent research regarding relatedilities (such as flexibility and survivability) were used as a basis to propose a set of design principles and architectural strategies that may result in, or at least correlate with, increased adaptability scores.

The third task focused on the valuation of adaptability—extension of the metric to include *worth*, incorporating the value of pursuing such adaptability by taking into account the effects of endogenous and exogenous perturbations that may face the system. Several techniques from real options analysis (Shah et al., 2008) and Epoch-Era Analysis (Ross, 2006; Ross and Rhodes, 2008; Viscito and Ross, 2009)) were pursued to illustrate a metric of “valuably adaptable”, including what conditions must hold and what additional data would be required in order to calculate this more “advanced” metric.

3. METHODS, ASSUMPTIONS and PROCEDURES

3.1 Methods and Assumptions

Prior MIT research on adaptability (changeability) has developed a theoretically sound, context bias-free definition of system change, as well as a taxonomy of types of change. This definition and taxonomy provide a basis for specifying, designing, and verifying that systems are capable of being changeable (Ross et al., 2008). This prior work, highlighted in the subsections that follow, provided foundational constructs and methods for further development in this research.

Assumption. The DARPA META-II program defines adaptability as “the ability of a system to change easily, quickly, and inexpensively (i.e., with minimum incurrence of cost and degradation in performance) in response to a wide spectrum of anticipated and unanticipated perturbation events exogenous or endogenous to the system. The explicit strategy in this, equivalent to maximizing utility, is only one of a number of possible strategies that we assume are of interest to DARPA in spite of not being explicitly stated. In this work we also investigated strategies for survivability of the system, maximizing efficiency, and maximizing profit.

3.1.1 Change Events as Paths

The construct of “change events as paths” is fundamental for a more precise understanding of a system change. A system change event can be characterized with three elements: (1) the agent of change, (2) the mechanism of change, and (3) the effect of change, as illustrated in Figure 1. The *agent of change* is the instigator, or force, for the change. The role of change agent can be intentional or implied, but always requires the ability to set a change in motion. The *mechanism of change* describes the path taken in order to reach a future state from the present state, including any costs, both time and money, incurred. Examples of mechanisms include the execution of real options, such as the swapping of modular components, or the procurement of additional system elements. The *effect of change* is the actual difference between the origin and destination states.

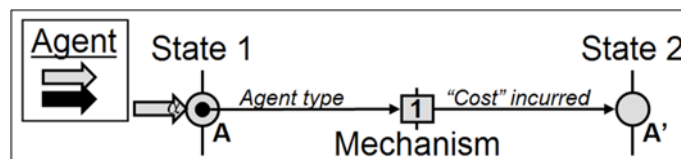

Figure 1. Change Defined as State Transition

The change described in Figure 1 is a simple case of one particular change. In the *agent-mechanism-effect* representation, a particular change is represented by a path. The changeability of a system is determined by how easily it can undergo various changes. Figure 2 shows an example of an expanded view with multiple change paths enumerated, where a change agent external to the system is termed a flexible change, and where the change agent internal to the system is an ‘adaptable’ change.

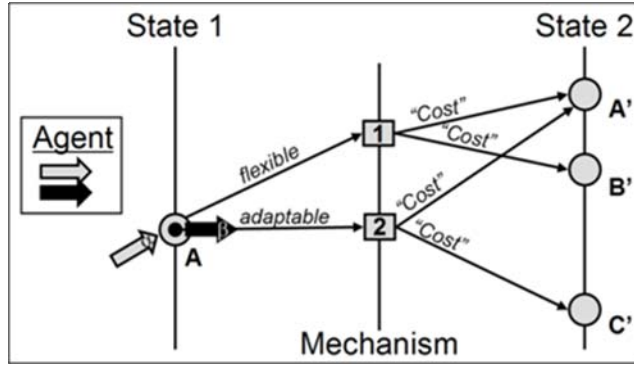

Figure 2. System Changes Depicted using Agents, Mechanisms, and Effects

Table 1 enumerates the example agents, mechanisms, and effects shown in Figure 2. For a particular system, many agents, mechanisms, and end states may be possible.

Table 1. Agents, Mechanisms, Effects, and Paths Shown in Figure 2

Element	Description	As Illustrated in Figure 2
<i>Change Agent</i>	<i>The force instigator for the change to occur, for example humans, software, Mother Nature, etc.</i>	α, β
<i>Change Mechanism</i>	<i>The particular path the system must take in order to transition from its prior to its post state, including conditions, resources, and constraints</i>	1, 2
<i>Change Effect</i>	<i>The difference in states before and after a change has taken place.</i>	$A'-A, B'-A, C'-A$
Potential Paths	<i>The potential paths for the system to change from one state to another.</i>	$\alpha:A-1-A', \alpha:A-1-B'$ $\beta:A-2-A', \beta:A-2-C'$

Figure 3 illustrates the notion of “perturbation” as an instigator for a *change pathway*: *perturbation-agent-mechanism-effect*. A perturbation can be exogenous to (outside of) or endogenous to (inside of) the system. The decision is made as to whether to execute a pathway.

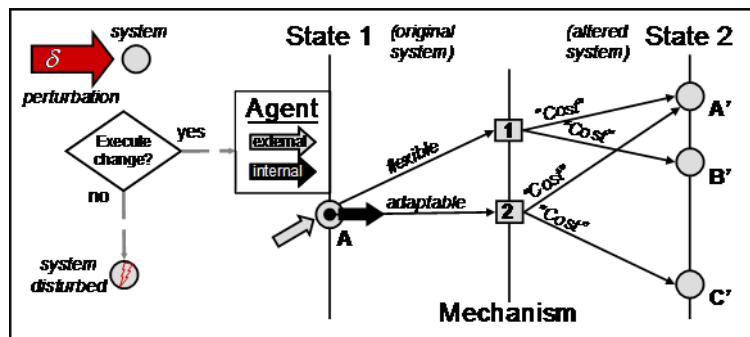

Figure 3. Change Pathway with Perturbation-Agent-Mechanism-State Change

3.1.2 Changeability Taxonomy Based on Change Pathway

The change agent location (internal or external to system) is a useful taxonomic distinction for classifying change. If the change agent is external to the system, then the change under consideration is a *flexible*-type change in this taxonomy. If the change agent is internal to the system, then the change under consideration is an *adaptable*-type change. Note that depending on the particular change being considered, a single system can be both flexible and adaptable. The definition of the system boundary must be explicitly defined in order to remove ambiguity when discussing whether a change should be considered as flexible or adaptable

3.1.3 Epoch-Era Analysis

Quantifying the changeability of a system necessitates bringing the dynamic aspects into consideration, as well as a *temporal value-based* perspective. Epoch-Era Analysis (EEA) (Ross, 2006; Ross and Rhodes, 2008) provides an approach for conceptualizing system timelines using natural value centric timescales, wherein the context itself defines the timescales. The full lifespan of a system is referred to as the *System Era*, which can be decomposed into *Epochs*. An Epoch is a period for which the system context has constant value expectations. Each fixed context is characterized by static constraints, available design concepts, available technology, and articulated attributes. As exogenous changes (e.g., new threat, availability of a new technology, new policy, etc.) trigger the start of a new epoch, the system may need to transform in order to sustain value in the new context, or else it may fail to meet expectations as defined for this new context, as illustrated in Figure 4 below.

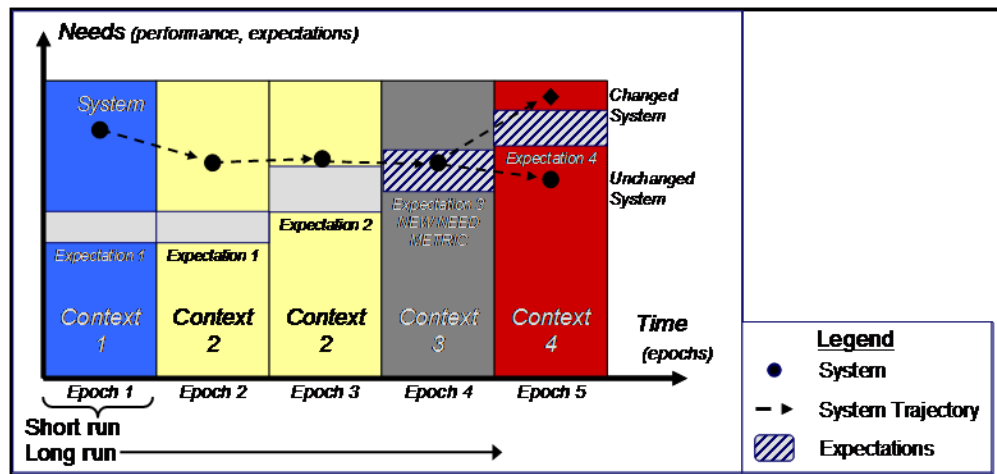

Figure 4. System Needs versus Expectations across Epochs of the System Era

Figure 4 illustrates the temporal evolution of a system as needs and contexts change. A system exists in Context 1 in Epoch 1 and has performance exceeding expectations. Expectations are represented by a band (gray shaded in figure) capturing the range from minimally acceptable to the highest of expectations. In Epoch 2, the context changes to Context 2 and the performance is degraded. Expectations are still met with the same system, so the system is relatively *robust* to the change in context. A change in expectation is shown in Epoch

3, with the context (“Context 2”) remaining the same as the second epoch; now the still unchanged system exhibits *value robustness* since it maintains value delivery in spite of changes in expectations. In Epoch 4, the system shows *versatility* by continuing to satisfy expectations despite the introduction of a new metric of need. Notice that even though the system no longer exceeds all expectations, it still does exceed the minimally acceptable level and thus is still successful. Finally, in Epoch 5, a change in context and a boost in expectations are too much for the system as-is; in this case the system must change in order to remain successful. If the system is capable of changing at acceptable cost, it is deemed *flexible* or *adaptable*, depending on the type of change desired (as determined by change agent – flexible, external agent; adaptable, internal change agent).

Epoch-Era Analysis provides an approach for visualization and a structured way to think about the temporal system value environment, and is used in our research approach as a useful mechanism for specifying strategies over time. The Epoch timelines can be assessed at any point during the system lifecycle, not only during early conceptual design. For analysis purposes, epochs can be known in advance, or in the moment, and can be deterministic, or probabilistic. As such, mathematical treatment of the paths, costs, utilities, and times must appropriately match the uncertainty level of the data.

Selection of the system Epoch end state is dependent on the strategy for the Epoch. No absolute correct or “best” design exists without subjectively specifying the “best” strategy. Strategies can include seeking maximum utility, minimum cost, minimum time, minimum risk, or any combination, among others. Strategies themselves can be predictive, adaptive, or static, meaning an analyst can use them to predict “best” paths for a system given present knowledge of the future, to adapt given new information about current and future epochs, or to statically drive a particular agenda for a fixed set of objectives and technology in a changing world. The system analyst can use the epoch analysis while the system is in operation, continuously updating probabilities and value data to determine the “best” path to other designs, as well as the “best” goal design to pursue in each epoch.

3.1.4 Tradespace Networks

The typical tradespace plot displays the system designs on a Cost-Utility space, showing the resources required (cost) and benefit delivered (utility) for systems in a concise format. A Pareto Set characterizes those “non-dominated” designs of highest utility at a given cost, across all costs, or those of lowest cost at a given utility, across all utilities. This set often shows the tradeoff of cost incurred for increased value. Considering each design as a potential starting or ending state for change, the tradespace frame suggests a mechanism for considering the changeability of system designs. If in addition to specifying design parameters (static representations of a system) designers also specify transition paths (dynamic change opportunities), a traditional tradespace can become a *tradespace network* (Ross and Hastings, 2006).

A network is a model representation of nodes and arcs. Each node represents a location, or state, with each arc representing a path that connects particular nodes. In a tradespace network, system designs are nodes and the transition paths are arcs. Each arc represents a transition with a “cost” in terms of both dollars and time. The transition paths represent each of the potential change mechanisms, with change agent, available to a particular design. Figure 5 shows a traditional static utility-cost tradespace transformed into a tradespace network after the specification of transition rules, which are used to generate transition paths between design

nodes. Designs that can follow more transition paths will have more outgoing arcs connecting it to other designs.

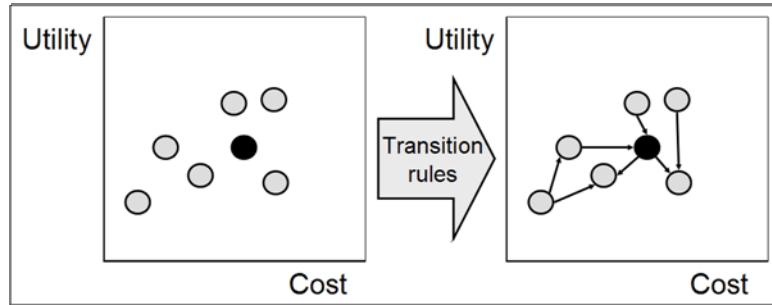

Figure 5. Tradespace Transformed into a Tradespace Network through Transition Rules

Figure 6 illustrates that when counting paths, one includes the agent-mechanism combination as a unique path. Each path has an associated cost with it, given the mechanism that is used to move the system from one state to another state

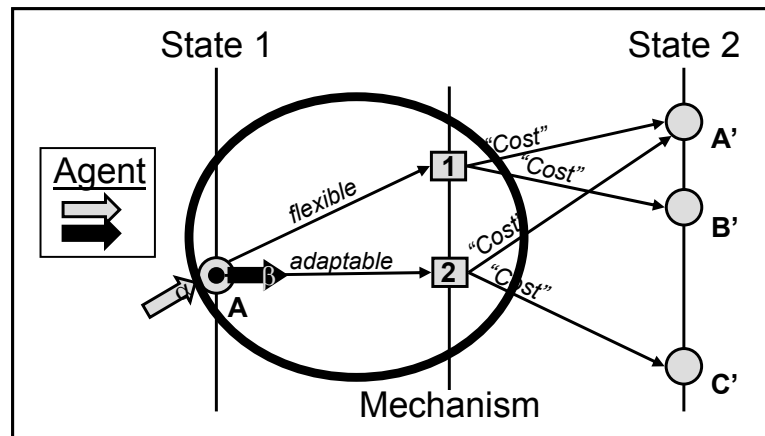

Figure 6. Path Counting including Agent-Mechanism Paths

3.1.5 Filtered Outdegree

The tradespace network representation provides a foundation for measuring changeability paths, given that each path will have a “cost” associated with its execution. Each decision maker will have an acceptability threshold for time or money spent for enacting change. The number of outgoing arcs from a particular design is called the *outdegree* for that design, as illustrated in Figure 8 (left). The number of outgoing arcs from a particular design whose cost is less than the acceptability threshold, \hat{C} , is the *filtered outdegree* for that design, as illustrated in Figure 7 (right) (Ross, 2006). The filtered outdegree is a quantification of the apparent changeability for a

design for a decision maker. The higher the filtered outdegree of a design, the more changeable it is to that decision maker. In the figure below, the outdegree counts the total number of change paths from a given design, state 1: A, to future designs, states 2: A', B', and C', shown with outdegree of four; (right) The filtered outdegree counts the number of change paths with acceptable cost, from a given design, state 1: A, to future designs, states 2: A', shown with filtered outdegree of two.

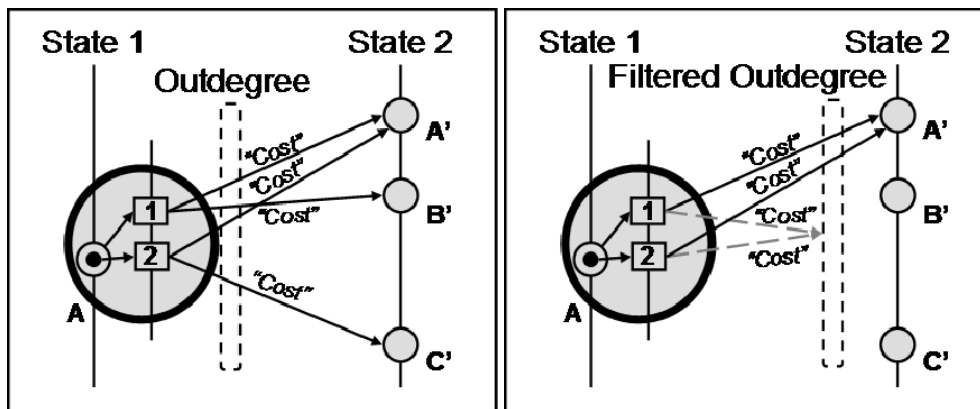

Figure 7. (left) Outdegree; (right) Filtered Outdegree

The objective, coupled with subjective nature, of the filtered outdegree captures the apparent relativity in perceived changeability of various designs: *what may be changeable to one decision maker may not be perceived changeable to another*. The subjective acceptability threshold differentiates the results per decision maker. Acceptability threshold “cost” can be on dollars, time, or any other resource that must be “spent” in order to follow a path. The objective outdegree calculation provides a mechanism for system designers to explicitly improve the potential changeability of a system: increase the number of outgoing arcs (add new transition rules), or reduce the cost of following outgoing arcs (increase the likelihood for arcs to cost less than acceptability threshold). The subjectivity in the filtered outdegree means that the setting of the threshold is subjective to the particular decision maker and his preferences for spending resources for change. The full outdegree, without filter, is an objective quantity upon which all people will agree, given a set of enumerated design variables and a set of transition rules.

3.1.6 Real Options Analysis for Valuing Changeability

Quantifying changeability is different than valuing changeability. The former is about “whether something is changeable,” while the latter is about “what is it worth” to have something changeable. Foundational work has been done in regard to valuation of real options and additional research is ongoing. The field of real options was motivated by the desire to apply quantitative financial options valuation methods to capital investment decisions. The term “real options” was first used by (Myers, 1984) in the context of strategic decision making, where “real” refers to the fact that the underlying asset is real rather than financial. A “real option” gives the decision maker the right, but not the obligation, to exercise an action or decision at a later point in time. The concept of real options analysis is to value investment decisions by

taking into account the options that are available to the decision maker in the future. In a general sense, any action or decision that can be taken in the future can be considered to be a real option.

Prior work on valuing flexibility has used real options analysis (Trigeorgis, 1998). To effectively use the real options approach, quantitative representation of the option's cost, future uncertainty, and possible exercised option outcomes are needed. Valuation of real options is done through mathematically collapsing future uncertain costs and benefits of the option into a common present value. Real options valuation has traditionally been applied to valuing business investment decisions under uncertainty (Copeland and Antikarov, 1998), but more recently have been applied to value flexibility in the context of system design under uncertainty (de Neufville, 2003; de Weck et al., 2004; Wang and de Neufville, 2006).

Three major approaches to valuing financial options are: Black-Scholes, binomial pricing, and simulation (Black and Scholes, 1973; Cox et al., 1979; Boyle 1977). All of these models have been used to value real options. However, the assumptions underlying the Black-Scholes model do not translate well to real options. The binomial pricing model and Monte Carlo simulation have been popular in valuing real options. Besides financial valuation models, decision analysis has been used to value real options. Decision analysis involves constructing a tree where the layers of nodes represent decision and chance outcomes alternatively. Uncertainties are modeled with probabilities of chance nodes. Decision analysis calculates the best decisions by maximizing the expected value of the outcomes. Real options valuation methods provide a means for quantitatively assessing decisions under uncertainty, but additional research is necessary to validate and evolve these methods, as real options differ significantly from financial options. For example, real options often have a high carrying cost, not typically incurred by financial options. Additionally, the execution of a real option may impact one's ability to exercise other real options. This coupling between real options introduces an additional cost for consideration during the analysis, which is not addressed in classical financial real options analytic methods.

A distinction has been drawn between 1) real options "on" projects (Copeland and Antikarov, 2001), referring to strategic decisions regarding project investments; and 2) real options "in" projects (Wang and de Neufville, 2006), which refers to engineering design decisions. The relationship between real options "on" and "in" projects is the subject of research in the MIT SEArI group (Mikaelian, 2008) examining under what situations it would make sense to invest in real options "in" versus "on" projects. For example, given the uncertain space system acquisition environment, how decisions can be made regarding whether to invest in changeability of a given spacecraft design versus investment in different missions or technologies.

3.2 Procedures

The research technical approach involved three major research tasks. The first was to develop an overall metrics assessment approach for guiding the means to select appropriate metrics for investigation and to evaluate these metrics in an appropriate time-dependent manner. The second task was to develop supporting metrics including the degree of changeability and value of changeability, as well as determining the applicability of each metric to the appropriate temporal strategy and data availability. The third task was to apply each metric to multiple data sets to evaluate candidate metrics, to demonstrate end-to-end application of the approach, and to demonstrate scalability.

In addition, the research team canvassed empirical data to identify a list of change mechanisms employed on real cyber-physical systems that can assist system designers in proposing change mechanisms for consideration.

Software was developed by the research team to demonstrate the end-to-end approach.

3.2.1 Assumption: Characteristics of Data Sets

The following are assumptions regarding the existing characteristics of data sets used in analysis:

- Data to characterize design alternatives (attributes, design variables) (Figure 8)
- Clearly defined context variables affecting perceived system value
- Variables needed to differentiate epochs (Figure 9)
- Must affect value in a significant/meaningful way for useful information to exist beyond a single epoch
- Change mechanism and cost data
- Requisite information for chosen changeability value metric
- Value must be able to be calculated for each epoch

	DV	2471	903	1687	2535	1909	3030	7156
Design variables	Inclination	90	30	70	90	70	90	90
	Apogee	460	460	460	460	1075	2000	770
	Perigee	150	150	150	290	150	150	350
	Com Arch	TDRSS	TDRSS	TDRSS	TDRSS	TDRSS	TDRSS	TDRSS
	Delta V	1200	1200	1200	1200	1200	1200	1000
	Prop Type	Chem	Chem	Chem	Chem	Elec	Elec	Chem
	Pwr Type	Fuel Cell	Fuel Cell	Fuel Cell	Fuel Cell	Fuel Cell	Solar Array	Solar Array
	Ant Gain	Low	Low	Low	Low	Low	Low	Low
Attributes	Data Life	0.51	0.51	0.51	10.05	0.52	0.61	11
	Lat Div	180	60	140	180	140	180	180
	Eq Time	5	11	6	5	2	2	5
	Latency	2.27	2.27	2.27	2.30	2.42	2.67	2.40
	Sample Alt	150	150	150	290	150	150	350
	Cost (\$10M)	4.21	4.21	4.21	4.88	4.52	4.99	4.15

Figure 8. Example of Design Variables and Attributes for each Design Considered

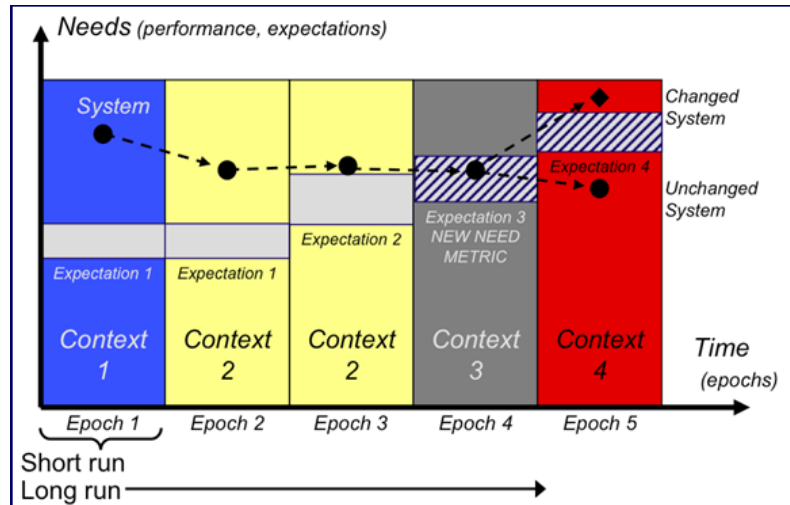

Figure 9. Illustration of Epochs Showing Variation in Contexts and Needs

4. RESULTS AND DISCUSSION

4.1 Results

4.1.1 Framing Concepts Leveraged from Prior Work

4.1.1.1 Change “Rules” and Mechanisms

To clarify the concept of change mechanisms and transition rules, the following describes these two concepts. A *change mechanism* is a method by which the system is change. For example “burn on board fuel” change mechanism results in a change in satellite orbit, costing “extra ops cost” for executing the maneuver (in this case the system “state” includes the operating orbit). A *transition rule*, also called *change rule*, is an algorithm that determines whether two proposed “states” are connected through a particular change mechanism. For example: “compare two ‘states’ and if difference is only fuel and orbit location, then if fuel difference is equal to amount burned to achieve orbit difference, then states have directed accessibility via change mechanism for cost determined by that mechanism.” The change rule is an operationalization of the concept of change mechanism in order to allow for computationally generated and evaluated alternative “paths” in a tradespace network, greatly automating the analysis process.

4.1.1.2 “Degree of” Change

One of the essential concepts to address in the research regarded the number of possible system end states reachable through available change mechanisms. In some sense, if a design has more reachable end states, that design is more changeable. Figure 10 displays a four quadrant view of differing numbers of mechanisms and end states. A given change mechanism may have some number of countable or uncountable end states. For example, a sleep number bed has 100 “levels” for firmness, corresponding to 99 alternative end states from a given starting state using the change mechanism of dialing the controller to inflate or deflate mattress-embedded air bladders using a pump. Alternatively, a design might have available more than one change mechanism, which also adds to the number of potential end states.

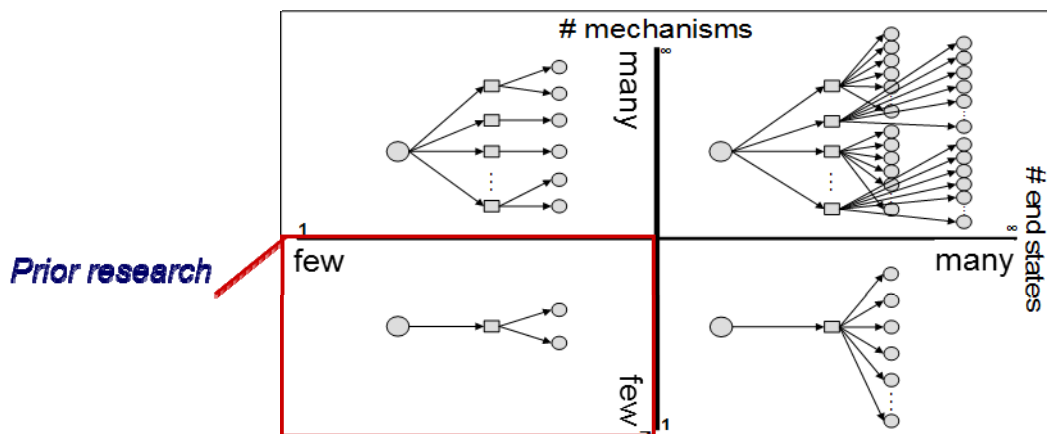

Figure 10. Degree of Changeability as a Function of Number of Mechanisms and End States

Prior research focused in the lower left quadrant of Figure 10, and a goal of this research effort was to expand to the other quadrants. On investigating the heuristic that “more end states is better” resulted in the following insights for why the number paths to end states might matter.

1. **Mechanism blocking.** One can conceive of instances where a particular change mechanism might become blocked, that is, unable to be executed. This blocking could occur as a result of a system failure, or imposed constraint, such as policy. For example a change mechanism may require the execution of prior-arranged contract agreement, but an ensuing policy directive prevents such relationship from taking place. Or one might purchase spare parts to allow for a “repair” change mechanism, only to find that the expert knowledge for conducting the “repair” was not available when needed years later. Having more change mechanisms allows a design to retain changeability even when one or more change mechanisms are blocked.
2. **Mechanism paring.** One can also conceive of instances where particular end states may no longer be available within execution of a particular change mechanism. For example, the pump needed in the sleep number bed example from above might become mechanically degraded resulting in a smaller range of possible firmness levels from 100 to 30. Certain destination orbits for a deployed satellite might become unusable due to orbital debris accumulating later in the lifecycle (thereby reducing the number of end states for the “change orbit” change mechanism. Having more possible end states for a given change mechanism allows a design to retain some changeability even when one or more end states are pared from a change mechanism.
3. **Uncertainty in desired goal end state.** One may also recognize that the desirability of a particular end state may be context dependent. That is, the particular mission in operations may change over time and the target end state for a system may not be what was anticipated earlier in the lifecycle. Having more possible end states allows for a design to have a higher likelihood of having a “good” end state available when the definition of “good” changes over time.

It is for the three reasons above, and shown in Figure 11, that the number of paths, which result from the available change mechanisms as well as possible end states, is related to the concept of valuable changeability and must be incorporated into the metrics.

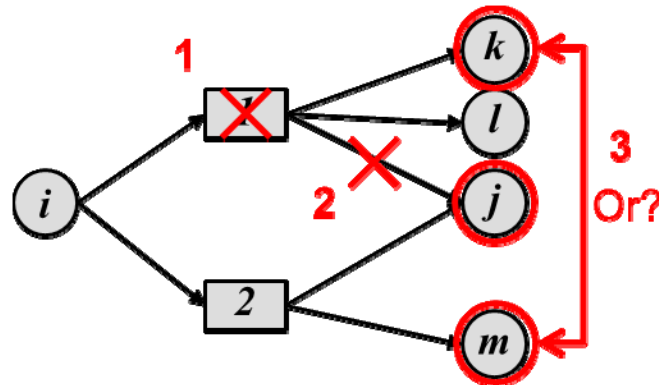

Figure 11. Justification for Need to Account for Number of Change Paths

It was determined that the number of paths is meaningful for accounting for changeability, however the enumeration of possible end states may become an intractable problem for change mechanisms with uncountable number of end states. Upon further investigation, the research team decided to recognize that there may be value in uncountable number of end states, however, value is determined only when change mechanisms are actually executed to a particular end state. This means the value of the path is dependent on the value of the “best” end state.

In order to clarify the tension between number (i.e. “degree”) of change paths, and the value (i.e. “magnitude”) of the end states explicitly in the changeability metrics, the concept of *rule execution strategy*, or just *strategy*, was proposed. The concept of strategy encapsulates the idea that “value is derived from changeability only with executed changes.” A strategy is a statement of how and when a stakeholder plans to execute any changeability options in the system. For example, “maximize utility,” or “exercise for survival only.” Given a defined tradespace network and epoch, a strategy will select the “best” transition (if any) that should be utilized from each design point, as can be seen in Figure 12.

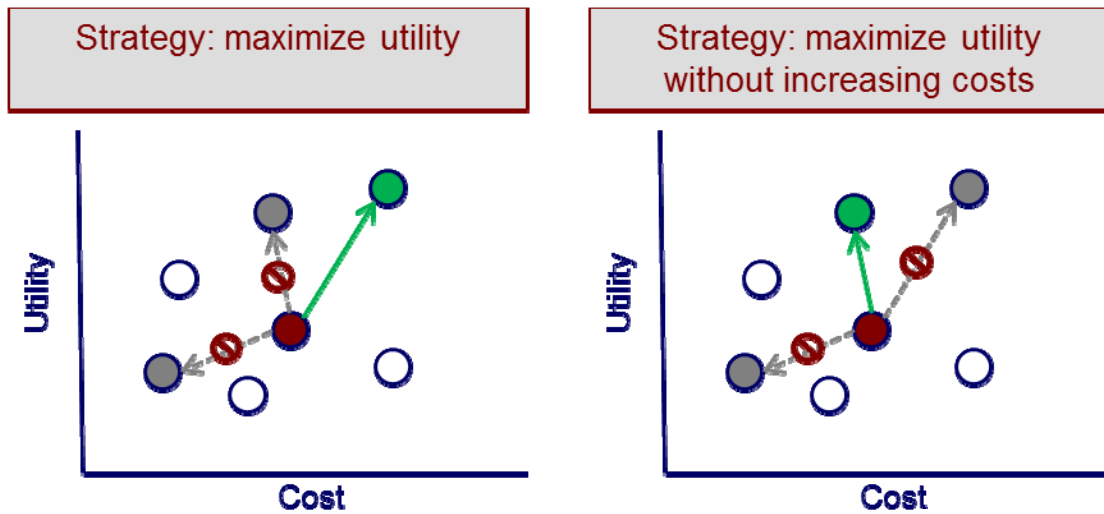

Figure 12. “Best” Path Selection Determined by Rule Execution Strategy

The concept of strategy reduces the burden of enumerating all possible end states. In practice, only “good enough” end states need to be enumerated in order for a strategy to show value in the changeability. Enumeration of better end states will result in higher value for the changeability given a strategy. In this way, confidence scales with effort and results can be gained without having to spend exhaustive effort to enumerate end states. In fact, numerical optimization and search methods can be used to generate target end states for a given strategy without having to enumerate full tradespace networks. This numerical search approach is recommended for future research.

4.1.1.3 Addressing “Counting” and “Magnitude” Value

Using the strategy-driven approach described in the last section, one can apply change rules to a tradespace to generate tradespace networks for each change mechanism, and then simplify the tradespace network by selecting the “best” path for each considered strategy.

As can be seen in Figure 13, the application of one (or more) strategies can vastly simplify a tradespace network, which represents the most valuable change path (change execution) for a given design-epoch pair. This then captures the “magnitude” aspect of valuable changeability. In order to re-incorporate the “counting” value of changeability, one must look across many epochs, both time-independent, and time-ordered, to see why having more than one of these valuable paths is worthwhile. This should account for blocking, paring, and uncertainty of desired end states. Having more end states will have an impact on: being more likely to have a high value transition under a given strategy; more likely to be valuable across multiple alternative strategies, more likely to retain valuable changeability when subject to unforeseen disturbances, such as loss of change mechanisms.

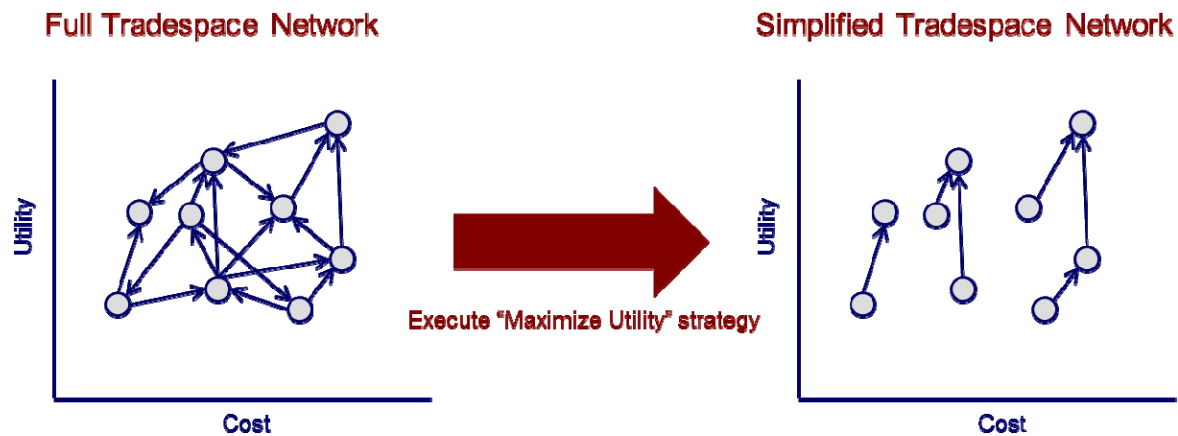

Figure 13. Tradespace Network Simplification via Strategy

4.1.1.4 Using Strategies for Short Run and Long Run Valuations

In addition to simplifying the tradespace network, the application of strategies helps to explicitly communicate various “usage” approaches to how changeability could be exploited, both in the short term (across a single epoch shift) and in the long term (across an era).

Strategies, such as “maximize utility” or “minimize operations costs” determine when to execute a change mechanism, typically in response to a perturbation, such as an epoch shift or disturbance. Across an era, many such perturbations might occur. The strategy is defined across an era and could be homogenous (applied in the same manner across any epochs) or heterogeneous (applied differently across particular epochs), as seen in Figure 14. Strategy formulation itself is not addressed in this research, however, this research does allow for comparison of the outcome of different strategies and could be used to explicitly communicate the difference in value of a change mechanism in the short run or in the long run.

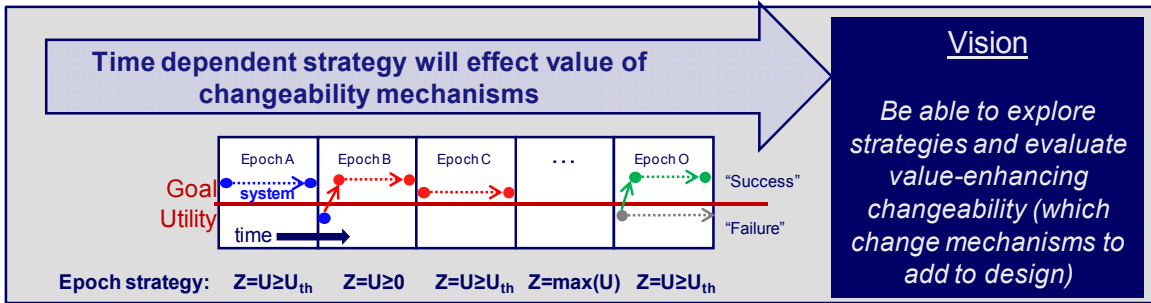

Figure 14. Epoch and Era Strategies Determine Value of Changeability

Looking across an era, automated analysis can be performed in order to compare the likelihood of executing particular change mechanisms as a function of strategy, as seen notionally in Figure 15. In this way, designers, analysts, and decision makers can see the implications of strategy on design choices to enable changeability. In particular, if certain change mechanisms are more feasible than others, the feasibility may constrain which strategies will extract the most value. This type of strategy comparison analysis will be conducted in the case studies in later sections of the report.

Rule \ Strategy	Likelihood of executing for strategy				Overall Rule Attractiveness
	Maximize Value	Maintain Value	Survive		
R1: Plane Change	❌ 5%	❌ 0%	❌ 0%	📊	2%
R2: Apogee Burn	⚠️ 20%	❌ 10%	✅ 40%	📊	23%
R3: Perigee Burn	❌ 5%	❌ 4%	⚠️ 20%	📊	10%
R4: Plane Tug	❌ 0%	❌ 0%	❌ 0%	📊	0%
R5: Apogee Tug	⚠️ 20%	❌ 0%	❌ 0%	📊	7%
R6: Perigee Tug	⚠️ 10%	❌ 0%	❌ 0%	📊	3%
R7: Space Refuel	❌ 5%	❌ 0%	❌ 0%	📊	2%
R8: Add Sat	✅ 30%	❌ 1%	❌ 5%	📊	12%
Do nothing	❌ 5%	✅ 85%	✅ 35%	📊	42%

Figure 15. Attractiveness of Change Rules by Strategy across an Era

4.1.2 Development of Metrics

A primary goal of this research effort is to develop a metric of “adaptability” (herein referenced as “changeability”). In order to develop the metric, a canvassing of existing metrics

was conducted, as well as a description of characteristics of a good metric, both of which are described below.

4.1.2.1 Necessity of Multiple Metrics for Changeability

Our investigation revealed that the multi-aspect nature of “valuable changeability” requires more than one metric. A set of metrics is needed to evaluate valuable changeability, determined by the system value sustainment strategy and context, as well as the availability of data. Metrics for valuable changeability must address the following tradeoffs:

- Design vs. Value
 - Function of design-only
 - Function of value-only
- Short run vs. long run
 - Per epoch evaluated
 - Across era evaluated
- Context specific vs. general
 - Epoch-specific
 - Epoch-general

These dimensions are illustrated in Figure 16, with example metrics that have been used in the literature that represent one of the aspects.

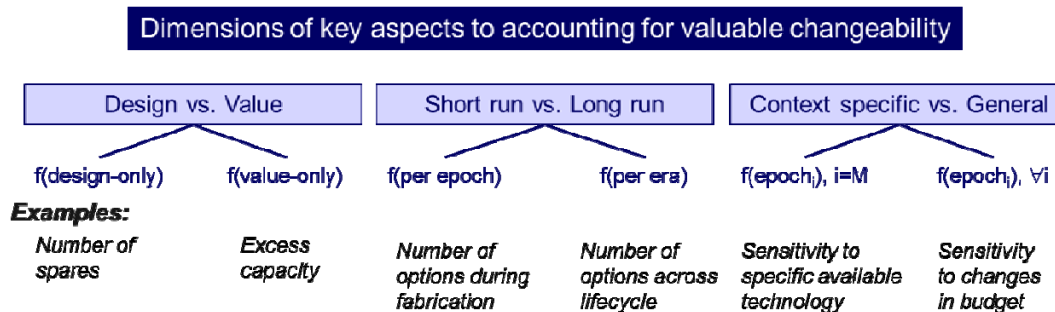

Figure 16. Conflicting Dimensions of Aspects to Account for Valuable Changeability

The metrics assessment approach guides the selection of appropriate metrics for a given valuable changeability assessment.

4.1.2.2 Empirical Metrics Comparison

Our early investigation included identifying metrics in the literature and in our prior work that would be candidates for evaluation. We qualitatively assessed these metrics, and identified the pros and cons, as shown in Table 2.

Table 2. Comparison of Metrics Studied in Investigation

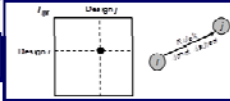
Name	Formula	What it measures	Pros	Cons
Filtered Outdegree	$FOD_i^m(\hat{C}) = \sum_j^N [Arc_{i,j}^m(\hat{C})]$	Counts # of cost-acceptable change paths	Conceptually simple, mostly function of design-only	Does not take into account benefit of end states, or degrees of cost
Normalized Filtered Outdegree	$NFOD_i^m(\hat{C}) = \frac{1}{N-1} \sum_j^N [Arc_{i,j}^m(\hat{C})]$	Non-unique fraction of tradespace accessible	Gives sense of "accessibility" of design space	(Same as FOD) Multiple paths to same point inflate measure
VWFO (v1)	$VWFO_i^{m,m-1}(\hat{C}) = \frac{1}{N-1} \sum_j^N [\text{sgn}(u_j^{m-1} - u_i^{m-1}) * Arc_{i,j}^m(\hat{C})]$	Fraction of "next" epoch utility-changing cost-acceptable paths available "now"	Accounts some for epoch-dependent destination benefit	Gains and losses can cancel, requires ordered pair-wise epoch analysis
VWFO (v2)	$VWFO_i^m(\hat{C}) = \frac{1}{N-1} \sum_j^N [H(u_j^m - u_i^m) * Arc_{i,j}^m(\hat{C})]$	Fraction of tradespace with utility-enhancing cost-acceptable change paths	Epoch-unique measure	Does not take into account degrees of cost or benefit;
Avail. Rank Increase	$ARI_i^m(\hat{C}) = \frac{r_i - r_j^{best}}{r_i - 1} Arc_{i,j,k}^m(\hat{C})$	Counts "best" rank improvement of change per rule	Avoids end state enumeration problems	Rank loses "degree of" benefit/cost, assumes benefit for cost tradeoff rate
Min Fuzzy Pareto K	Algorithmically determined as non-dominated up to some fraction (K) of objective range mark indicates allowed transition from design i to design j using rule k	Utility-cost efficiency gains	Addresses both costs and benefits	Must use proper "costs" (e.g. execution cost)
			$Arc_{i,j}^m(\hat{C}) = \sum_k^R H(T_{i,j,k}^m) \sqrt{T_{i,j,k}^m} < \hat{C}$	

4.1.2.3 Evaluating Potential Changeability Metrics

One of the resulting conclusions derived in our metrics investigation was that a good metric for adaptability should meet certain criteria. These include:

- Independent of design space enumeration – where value is define intrinsically rather than relative to other designs
- Basis is universal – the value of ‘metric x’ is equal to the value of ‘metric x’ regardless of variable changes (epoch, design, rule, etc.)
- Values both magnitude and number of changes in that both of these provide value but in different ways. Magnitude value implies a change resulting in greater utility than another is more valuable. Number of changes (counting value) implies that having two change options is better than one.

As can be seen in

Table 3, no single metric meets all of the desired criteria for a single valuable changeability metric. Instead, what was determined was to use a set of metrics to gain insight into the various trade-offs described above and collectively meeting the desirable criteria.

Table 3. Potential Valuable Changeability Metrics Evaluated by Criteria

Metric	Independent	Universal	Magnitude	Number
Filtered Outdegree	Maybe	No	No	Yes
Normalized FOD	Maybe	Yes	No	No
Value-Weighted FOD	Maybe	No	Maybe	Yes
Available Rank Increase	No	Yes	Yes	No

It was determined over the course of the research that if the goal of changeability is value sustainment, or at least “effectively” responding to perturbations, then in addition to changeability, some concept of “robustness” should also be considered since it represents the “do nothing” change mechanism. In identifying potentially “interesting” designs for the analysis, including such designs forms a natural point for comparison for highly changeable designs. Table 4 above lists the set of changeability metrics that were refined over the course of the research and incorporated in the valuation approach in order to extract the valuable changeability information regarding design decisions, strategies, epochs, and change mechanisms over a system lifecycle. These metrics will be illustrated in the valuation approach description, as well as the case applications that follow.

Table 4. Final Set of Valuable Changeability Metrics

Aspect of Valuable Changeability	Acronym	Stands For	Definition
Robustness via “no change”	NPT	Normalized Pareto Trace	% epochs for which design is Pareto efficient in utility/cost
Robustness via “no change”	fNPT	Fuzzy Normalized Pareto Trace	Above, with margin from Pareto front allowed
Robustness via “change”	eNPT, efNPT	Effective (Fuzzy) Normalized Pareto Trace	Above, considering the design’s end state after transitioning
“Value” gap	FPN	Fuzzy Pareto Number	% margin needed to include design in the fuzzy Pareto front
“Value” of a change	FPS	Fuzzy Pareto Shift	Difference in FPN before and after transition
“Value” of a change	ARI	Available Rank Increase	# of designs able to be passed in utility via best possible change
Degree of changeability	OD	Outdegree	# outgoing transition arcs from a design
Degree of changeability	FOD	Filtered Outdegree	Above, considering only arcs below a chosen cost threshold

4.1.3 Valuation Approach for Strategic Changeability (VASC)

Given that a number of metrics address various important aspects of valuating changeability, an “approach” was developed to aid in applying these metrics in order to uncover difficult-to-extract information on valuable changeability for a design space and present it in an accessible way to assist in decision making. Other goals included:

- Identify designs which deliver high amounts of value in different ways (robustness, changeability), and the operational strategies that maximize value
- Assess what change mechanisms deliver the most value or are the most critical for some designs to function well
- Establish cost/benefit tradeoff for adding/removing changeability from a design

What follows is a summary of the five step approach to valuating changeability.

Valuation Approach for Strategic Changeability (VASC)

1. Set up data for epoch-era analysis
2. Identify designs of interest
3. Define rule usage strategies
4. Conduct multi-epoch changeability analysis
5. Conduct era simulation and analysis

4.1.3.1 Set Up Data for Epoch-Era Analysis

Step 1 puts the case in question into the epoch-era framework, allowing for piecewise consideration of time in sequences of constant-context sections. Activities include identifying input data (design variables, change mechanisms, stakeholder preferences and desired attributes, and context variables). Outputs include design/epoch lists, transition matrices, and Fuzzy Pareto Number for each design/epoch pair.

4.1.3.2 Identify Designs of Interest

Step 2 is necessary to reduce both the computation time and the difficulty of synthesizing and grasping the results of the approach by reducing the scope of our full attention. Activities include calculating changeability screening metrics (e.g. Normalized Pareto Trace and Fuzzy Normalized Pareto Trace for value robust designs, and Filtered Outdegree for highly changeable designs), and any other desired design identification techniques (such as picking favorite designs through reuse or high performance in other metrics). Outputs include a subset of designs for further exploration. If concurrent visualization for comparison is desired, then the number of designs in this set should be on the order of 5-7 for clarity purposes.

4.1.3.3 Define Rule Usage Strategies

Defined in step 3, the strategy is the unifying factor of the method, specifying the logic that interprets the system condition over time and identifies change mechanism options that should be executed. Activities include determining the set of possible rule usage strategies, defining strategies in terms of logic for change mechanism execution in each epoch, and for each design/epoch pair, determining the most desirable end state (defined by the strategy), which is reachable via transition rules. Outputs include the realized end states and transition costs for each combination of design/epoch/strategy.

4.1.3.4 Conduct Multi-Epoch Changeability Analysis

In step 4, multi-epoch changeability analysis considers possible situations the system could be used in, but without the complication of time ordering or time dependence. Activities include calculating multi-epoch metrics, such as Effective NPT and Effective Fuzzy NPT, Fuzzy Pareto Shift, Removal Weakness, and Available Rank Increase. Outputs include information on when, why, and how designs of interest are changing within epochs and the value of those changes, as well as identification of particularly valuable change mechanisms and/or designs which rely on a single mechanism for a large portion of their value.

4.1.3.5 Conduct Era simulation and Analysis

In step 5, sample eras give important lifecycle information on the designs as they perform, change, and age over time, as well as help identify valuable change mechanisms. Activities include simulation of many randomly generated potential eras for each design of interest. Outputs include change mechanism usage frequency and likelihood, era-level statistics on average/aggregate utility provided and design efficiency, and comparison of strategies and change mechanism usage for each design.

4.1.3.6 Metrics Usage in VASC

Each of the metrics developed in the course of this research addresses a different aspect of the conflicting dimensions for valuating changeability highlighted earlier. Table 5 lists the metrics from Table 4 and to which step in VASC its use is most applicable. The intent for the later metrics is for design implications (change mechanism investment) and strategic decision making (i.e., what strategy to pursue, and cost vs. benefit of changeability features).

Table 5. Metrics with Relation to Changeability Aspects and VASC Step

Metric	Robustness vs. Changeable	Short Run vs. Long Run	VASC Step
NPT, fNPT	robustness	Short run	2: screening
FOD	changeable	Short run	2: screening
eNPT, efNPT	changeable/ robustness	Short run	4: multi-epoch
FPS	changeable	Short run	4: multi-epoch
ARI	changeable	Short run	4: multi-epoch
Avg FPN	robustness	Long run	5: era analysis
Rule usage	changeable	Long run	5: era analysis
“going rate”	changeable/ robustness	Long run	5: era analysis

4.1.4 Case Applications

Several case applications were performed on existing data sets in order to develop the metrics and valuation approach, as well as validate and determine the scalability/deployability of the approach. The first case application, X-TOS was used for development. The second and third case applications were used for validation and deployability testing.

4.1.4.1 X-TOS Case Study

The primary purpose of the application of the X-TOS case in this research investigation was twofold: (1) to serve as an experimentation case to develop the metrics assessment approach, and (2) to test the various adaptability metrics identified through empirical investigation.

Background. X-TOS is a proposed particle-collecting satellite designed to sample atmospheric density in low Earth orbit. A full Multi-Attribute Tradespace Exploration (MATE) study was performed in 2002 to analyze potential designs for the system. For the study, 8 design variables were mapped into 7840 designs with 5 utility-generating attributes; the variables and related attributes are detailed in Table 6. Additionally, multiple-satellite configurations were tested, but not included in the final tradespace due to vastly increased cost for only marginal increased utility. Changeability was noted to be highly desirable in the X-TOS final report, because an unknown parameter (atmospheric density, which the system was designed to measure) had a large impact on the performance of the satellite.

Table 6. X-TOS Case Design and Value Attributes

Design Variable	Directly Associated Attributes
Apogee	Lifetime, Altitude
Perigee	Lifetime, Altitude
Inclination	Lifetime, Altitude, Max Latitude, Time at Equator
Antenna Gain	Latency
Comm. Architecture	Latency
Propulsion Type	Lifetime
Power Type	Lifetime
ΔV Capability	Lifetime

In 2006, the X-TOS study was revived as a case study for a research effort to quantify changeability (Ross and Hastings 2006 **Error! Bookmark not defined.**). Using the change agent-mechanism-effect framework, 8 transition rules were created allowing for the change from one design point to another. The rules are listed in

Table 7. It should be noted that the “tugable” and “refuelable” designations were added

Table 7. It should be noted that the “tugable” and “refuelable” designations were added as design variables, to be included at a fixed cost as enablers for the appropriate change mechanisms. The study encompasses Adaptability (i.e., SEArI adaptability and flexibility), as the “burn fuel” change mechanism responds to an internal agent (adaptable), while the others respond to external agents (flexible). There is also an appreciable spread in costs, as the Burn Fuel mechanism is modeled to cost orders of magnitude less to employ, in both time and money, than the others.

Table 7. X-TOS Rules (Change Mechanisms)

Rule	Description	Change agent origin
R1: Plane Change	Increase/decrease inclination, decrease ΔV	Internal (Adaptable)
R2: Apogee Burn	Increase/decrease apogee, decrease ΔV	Internal (Adaptable)
R3: Perigee Burn	Increase/decrease perigee, decrease ΔV	Internal (Adaptable)
R4: Plane Tug	Increase/decrease inclination, requires “tugable”	External (Flexible)
R5: Apogee Tug	Increase/decrease apogee, requires “tugable”	External (Flexible)
R6: Perigee Tug	Increase/decrease perigee, requires “tugable”	External (Flexible)
R7: Space Refuel	Increase ΔV , requires “refuelable”	External (Flexible)
R8: Add Sat	Change all orbit, ΔV	External (Flexible)

Finally, 58 different epochs were generated to extend the study into epoch-era analysis. In this case, the epochs were generated by perturbing the defined stakeholder utility preferences of the MATE study in one of four ways: adding/removing attributes, reweighting the attributes, linearizing the attribute utility curves, and altering the multi-attribute utility aggregation function. These epochs form a basis for a “what if?” analysis of the future, addressing such design process uncertainties as “What if we selected the wrong attribute set?” or “What if the stakeholder changes preferences?”. This is an acceptable method of generating epochs, although ideally the stakeholder would be available to re-derive his preferences for different potential scenarios in the system’s future such as a goal change or wartime conditions.

Step 1: Set Up Data for Epoch-Era Analysis

Initiating the method requires the proper construction of an epoch-differentiated data set. To reiterate, *epochs* are defined as periods of time during which the system operates in a particular fixed context and set of needs. An epoch is defined by a set of *epoch variables*, which must be enumerated. Epoch variables should include any and all situational or operational conditions that will change over time and significantly impact the system’s delivery of value. The epochs must differentiate the candidate designs in value or the results of the method will be simply a repetitious version of a static context study; for this reason, selecting value-affecting epoch variables is a critical step towards investigating the value-over-time characteristics of different designs. Epochs are differentiated by varying stakeholder preferences in four ways: (1) Changing value-delivering attribute set; (2) Changing attribute weightings in multi-attribute utility function; (3) Linearizing attribute utility curves; and (4) Different utility aggregating functions. The epochs are enumerated one at a time as perturbations from the base case are never applied simultaneously. These epochs represent anticipatory exploration of possible preferences, helping to answer “what if” questions, such as:

- What if you don’t elicit the “right” requirements/preferences (attributes)?
- What if you don’t elicit the “right” attribute priorities?
- What if you don’t elicit the “right” utility curve shape?

More specific epochs can be created by actually re-deriving the utility curves with the stakeholder for different hypothetical situations (mission goal change, wartime, etc.)

Step 2: Identify Designs of Interest

It is useful to use a set of screening metrics in order to reduce the number of designs considered in full detail to a manageable amount (on the order of 10 instead of the entire tradespace). One such metric is Normalized Pareto Trace (NPT), which identifies designs that are passively value robust: cost-utility efficient in a large number of epochs. NPT is plotted for the entire space in Figure 17, with Design 31 highlighted as the best-NPT design. Design 31 is thus a candidate for further investigation, as it might be expected to perform well based on its robustness. By considering Fuzzy Normalized Pareto Trace (fNPT), designs that are nearly cost-utility efficient will also be identified: Figure 18 shows this plot and highlights Designs 1, 345, 689, and 2759. Note that these are not the only designs with an fNPT of 1; they were selected to provide as broad a range of the design variables as possible. If VASC is iterated a second time on other designs of interest, there are many options here.

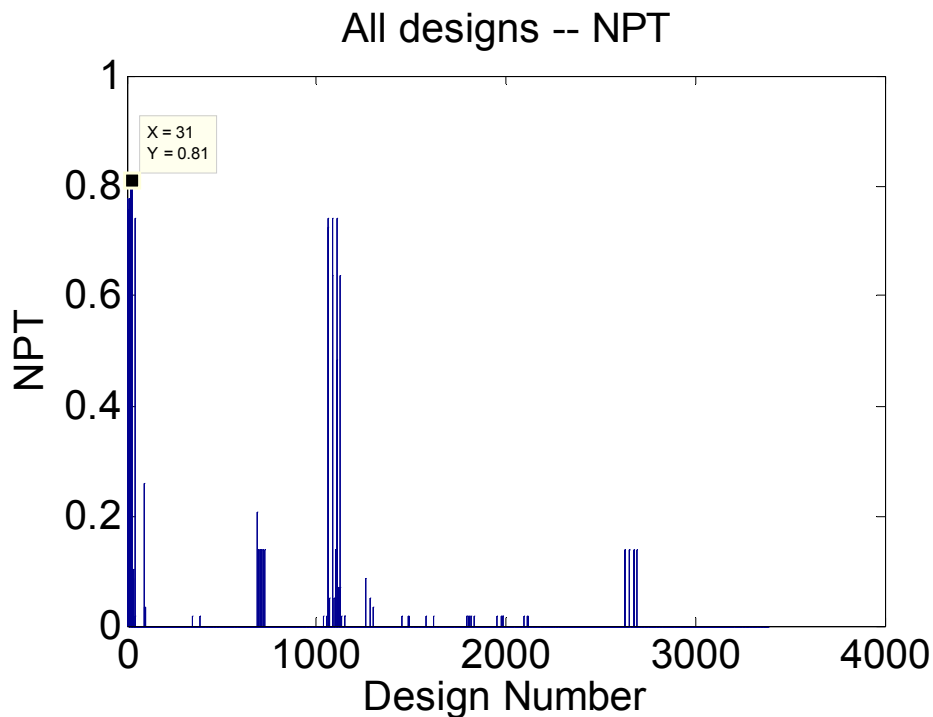

Figure 17. X-TOS - Design Space NPT

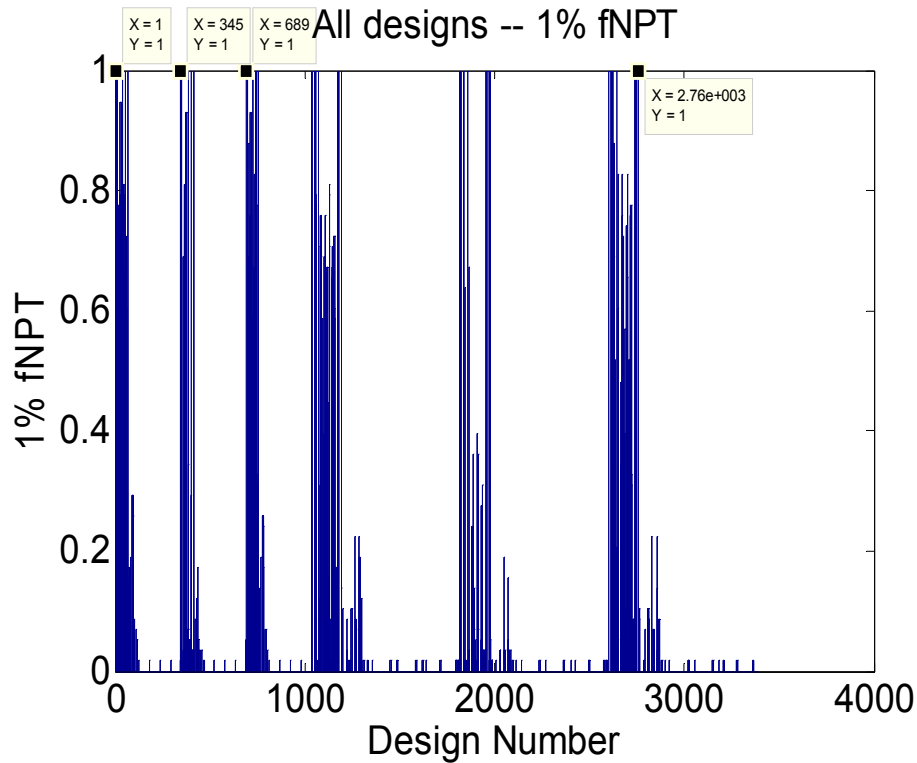

Figure 18. X-TOS - Design Space fNPT

Another useful screening metric is Filtered Outdegree (FOD), which can be used to identify designs with a large number of outgoing change arcs. Heuristically, these designs are expected to derive more value from changeability because of their increased number of options; this will be tested with the rest of the VASC process. Varying the filter in the FOD equation allows designs to be found with large numbers of options available for different levels of acceptable transition cost; this can be useful because a design with a large number of cheap transition options but not the most options overall may provide a less expensive alternative. Figure 19 shows the FOD for the design space at two different thresholds: one essentially unlimited (10^{10} dollars and seconds) and the other quite limited (10^3 dollars and 10^5 seconds), identifying four more designs of interest.

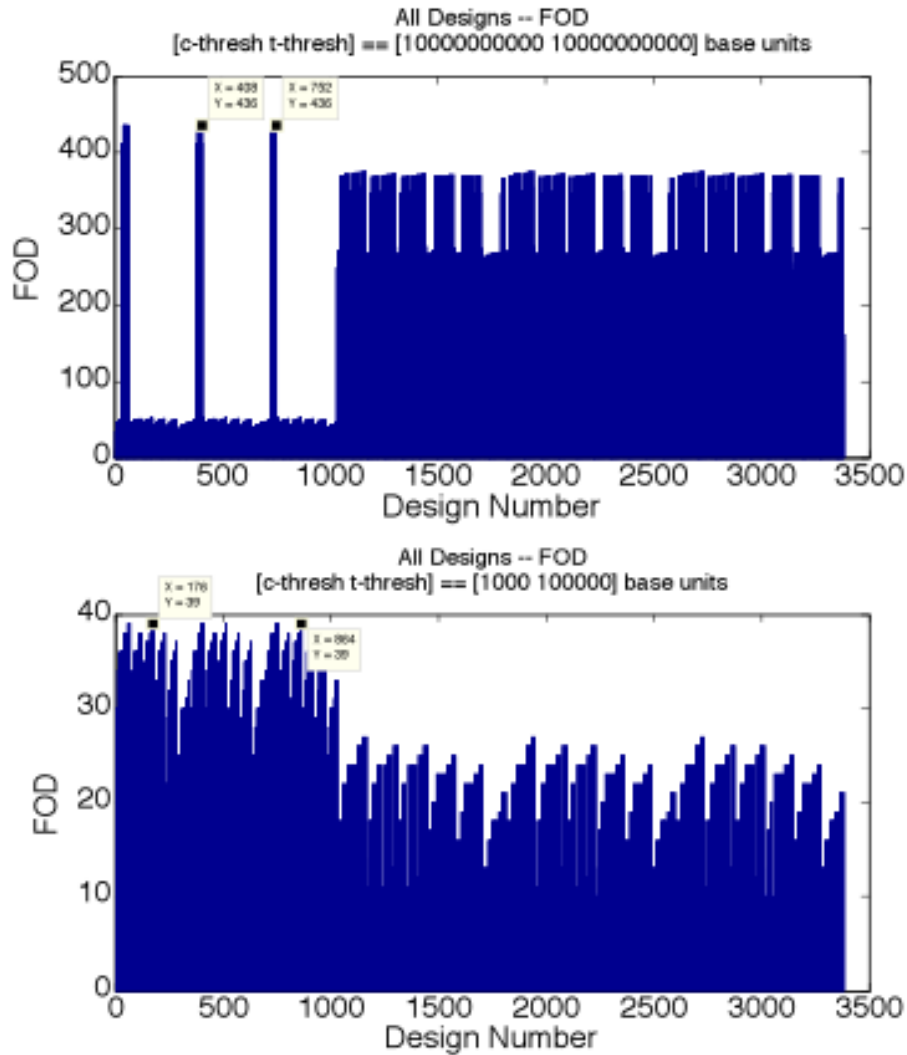

Figure 19. X-TOS - Design Space FOD for Two Thresholds

The selected designs of interest are listed in Table 8 with the respective values of their design variables and a reference letter to be used in future plots. Note that the screening metrics selected only designs with chemical propulsion: this is a first-order insight suggesting that chemical propulsion is dominant over the other options (in this case, electric). If the decision maker feels that electric propulsion carries some positive characteristic which is not being captured by the utility function or the screening metrics, VASC could be repeated with a different set of designs of interest, focusing on electric satellites. Also of interest is the fact that three of the designs identified here match the set of designs of interest used in the 2006 X-TOS changeability study, suggesting that the screening metrics are in line with previous expert insights.

Table 8. X-TOS Case Study Designs of Interest

Design #	Reference	Inclination	Apogee	Perigee	Delta V	Prop Type	Power Type	Ant. Gain
1	A	30	458.33	150	1200	Chem	Fuel	Low
31	B	30	458.33	283.33	1200	Chem	Fuel	Low
176	C	30	1075	350	1200	Chem	Solar	High
345	D	70	458.33	150	1200	Chem	Fuel	Low
408	E	70	458.33	350	100	Chem	Solar	High
689	F	90	458.33	150	1200	Chem	Fuel	Low
752	G	90	458.33	350	100	Chem	Solar	High
864	H	90	1075	350	1200	Chem	Solar	High
2759	I	90	766.67	216.67	400	Chem	Fuel	Low

Step 3: Define Rule Usage Strategies

For X-TOS, two strategies are considered: (1) *maximize utility* and (2) *maximize efficiency* (as measured by Fuzzy Pareto Number, FPN). These are basic strategies that target simple measures of system performance at any cost, but serve well to predict how a stakeholder may choose to use the system.

Maximize Utility: Make system as good at its job as possible (highest reachable utility per epoch).

Maximize Efficiency: Desire to be as cost-utility efficient as possible.

After picking the strategies, a MATLAB® script finds the executed transition (if any) for each design in each epoch with each strategy, which feeds into the following steps.

Step 4: Conduct Multi-Epoch Changeability Analysis

Table 9 shows the NPT of the designs of interest side by side with the Effective Normalized Pareto Trace (eNPT) resulting from each strategy. *Maximizing efficiency* clearly results in an increase from NPT to eNPT for each design because the strategy does not allow for changes that move designs away from the Pareto Front. The *maximize utility* strategy results in a decrease for most designs, as greater utility can be achieved, but with diminishing returns on costs, thus reducing efficiency and moving away from the Pareto Front.

Table 9. X-TOS - NPT and eNPT

Design	Do Nothing (NPT)	Max U	Max Eff
A	0.776	0.103	1
B	0.810	0.103	1
C	0	0	0.052
D	0.017	0.086	1
E	0	0	0.052
F	0.207	0.086	1
G	0	0	0.052
H	0	0	0.052
I	0	0	1

Table 10 shows the corresponding fNPT and Effective Fuzzy Normalized Pareto Trace (efNPT) of the designs of interest with a 1% fuzziness, and improvements over the “not-fuzzy” values highlighted in green. Obviously, all of the designs of interest perform well in these metrics across most epochs when allowed to execute transitions and when allowing for a small margin of fuzziness in defining efficiency.

Table 10. X-TOS - 1% fNPT and efNPT

Design	Do Nothing (fNPT)	Max U	Max Eff
A	1	1	1
B	0.948	1	1
C	0	0.879	0.914
D	1	1	1
E	0	0.879	0.914
F	1	1	1
G	0	0.879	0.914
H	0	0.879	0.914
I	1	1	1

Table 11 and Figure 20 below show the FPS distributions and order statistics for the designs of interest under the *maximize utility* strategy. Comparing the Fuzzy Pareto Shift (FPS) distributions of the designs of interest is the main focus of this step of VASC, as it allows for an understanding of the similarities and differences between the designs. Designs A and B, which

were high NPT selections, obviously do not transition frequently, as visible in the large spike at zero FPS, although B does have a +40 FPS for one epoch in which it performs poorly. Designs C and H appear to derive the most value from their changeability under this strategy; each has a spike in the low twenties range that comprises about half of the epochs in the epoch space, with no epochs causing a reduction in efficiency and a few high outliers over sixty. E and G also perform well, with consistent improvement of around 7% efficiency in most epochs. The table provides a slightly less cluttered view of the same information, with the results highlighted by a heat map from red (bad) to green (good). Note that order statistics are presented and not mean or standard deviation: since FPS distributions are frequently skewed (as they are here), the mean is a misleading measure of central tendency.

Table 11. X-TOS - Maximize Utility FPS Statistics

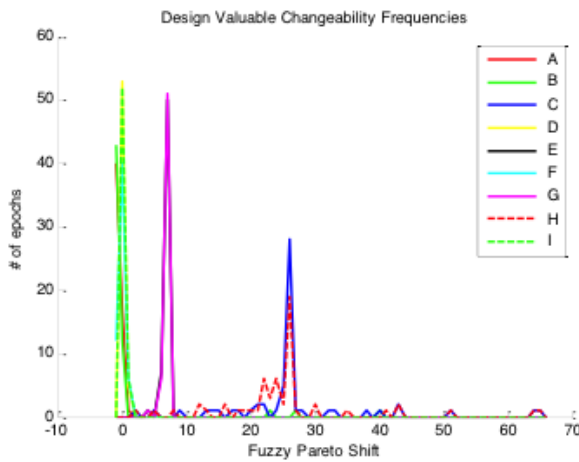

	Min	1st Q	Med	3rd Q	Max
A	-1	-1	-1	0	1
B	-1	-1	-1	0	40
C	2	25	26	26	65
D	0	0	0	0	1
E	4	7	7	7	7
F	-1	0	0	0	1
G	4	7	7	7	7
H	2	22	25.5	26	65
I	0	0	0	0	1

Figure 20. X-TOS - Maximize Utility FPS Distribution

Table 12 and Figure 21 show the same information but for the *maximize efficiency* strategy. The designs perform largely similarly to the *maximize utility* strategy, with the exception of the few negative performances becoming zeros because this strategy does not allow for negative FPS changes.

Table 12. X-TOS - Maximize Efficiency FPS Statistics

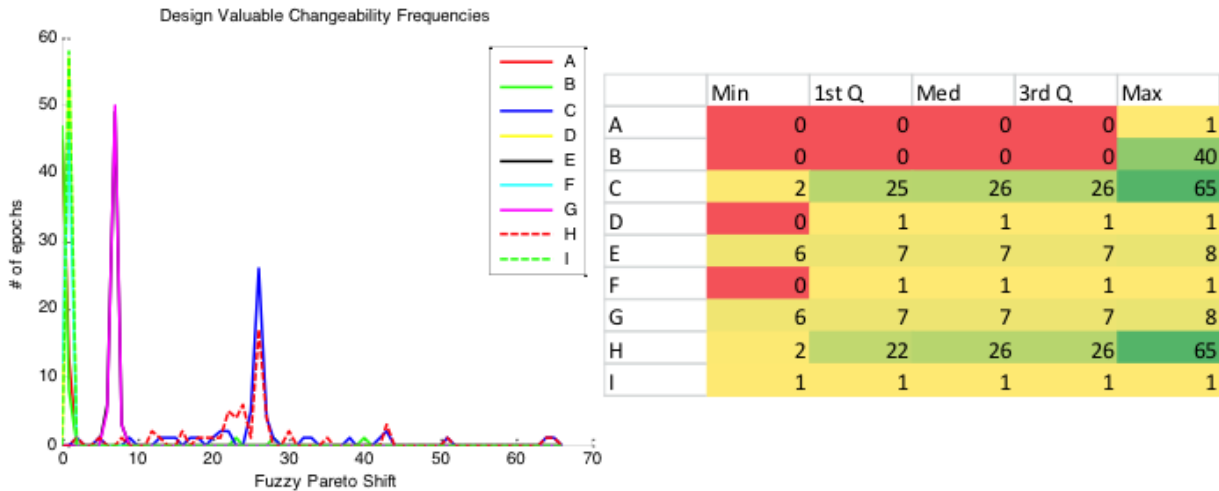

Figure 21. X-TOS - Maximize Efficiency FPS Distribution

Step 5: Conduct Era Simulation and Analysis

A simple era constructor was created in MATLAB® for the purposes of this case study. The era constructor rules are defined as follows:

1. 20 randomly selected epochs
2. Each epoch is 1 year in duration

This is a very simple era constructor, but it encompasses the basic features desired by this particular study. Since the epochs vary only by preference set, the goal of era analysis is to understand the performance effects of uncertain varying preferences over time (the long run) and, in particular, the use of the change mechanisms. This makes features such as varying epoch lengths or more sophisticated sampling of epochs unimportant, although they could be implemented as well.

One thousand eras were constructed and analyzed for each candidate design in the study. As the trials were running, the total dollar cost, time cost, and number of changes were recorded, to be averaged at the end, along with tracking of FPN across the era and transition usage by change mechanism. That data is presented in

Table 13, and it reveals a number of interesting outcomes.

Table 13. X-TOS – Era Analysis Results

Max Utility					Max Efficiency				
Design	Avg # Trans.	Avg Total Trans Cost	Avg Total Trans Delay	Avg FPN	Design	Avg # Trans.	Avg Total Trans Cost	Avg Total Trans Delay	Avg FPN
A	19.9	\$386M	2.91 yrs	2.76	A	7.5	\$271M	2.97 yrs	1.99
B	19.9	\$382M	2.86 yrs	2.73	B	7.1	\$260M	2.85 yrs	2.21
C	19.8	\$396M	2.96 yrs	5.54	C	10.3	\$319M	3.44 yrs	5.18
D	19.9	\$422M	3.34 yrs	2.69	D	8.3	\$310M	3.38 yrs	2.22
E	19.9	\$432M	3.42 yrs	4.47	E	10.2	\$335M	3.66 yrs	4.19
F	19.8	\$420M	3.32 yrs	2.68	F	8.0	\$300M	3.25 yrs	2.23
G	19.8	\$425M	3.33 yrs	4.68	G	10.2	\$329M	3.59 yrs	4.17
H	19.8	\$419M	3.25 yrs	5.47	H	10.1	\$306M	3.30yrs	5.06
I	19.9	\$422M	3.34 yrs	2.64	I	8.4	\$314M	3.41 yrs	2.28

First, it is obvious that *maximizing utility* requires a transition at nearly every epoch switch. This makes sense considering that the epochs define different preferences and thus, assuming that the preferences change enough to differentiate themselves, each epoch will have a different best-utility design reachable by the system. It is also apparent that, despite fewer transitions and lower amounts of money spent on transitions, the *maximize efficiency* strategy has approximately the same amount of time delay from transitions (3 out of 20 years, ~15%). Finally, by tracking FPN across the era, we can take the average FPN as a measure of the lifetime cost efficiency of the system, which varies between 2% and 5% inefficient for the different designs of interest: a relatively small variation. Thus, it appears that the designs are all quite similar in operation given the changeability strategies used here, with a slight advantage to the *maximize efficiency* strategy and passively robust designs (A,B) for their lower expected transition costs.

Identifying why the designs have such similar performances is potentially interesting. By looking at the transitions selected by each strategy, likelihoods for using each change mechanism for a random epoch switch can be calculated. These are presented in Table 14. The two most common mechanisms are *Perigee Burn* and, surprisingly, *Redesign*. Perhaps this sort of behavior is not what is desired or expected in the system; the stakeholder may want to find a design that is functional over an era without needing to redesign. To address this, a rule removal weakness study can be performed.

Table 14. X-TOS - Change Mechanism Usage Likelihood (Random Epoch Switch)

	Design	Inclination	Apogee	Perigee	Inclination	Apogee	Perigee	Refuel	Redesign
		Burn	Burn	Burn	Tug	Tug	Tug		
Max Utility	A	0	0.02	0.93	0	0	0.05	0	0.17
	B	0	0.02	0.93	0	0	0.02	0	0.17
	C	0.17	0.72	0	0	0.10	0.79	0	0.17
	D	0	0	1.00	0	0	0	0	1.00
	E	0	0.02	0.86	0	0	0	0	1.00
	F	0	0	1.00	0	0	0	0	0.84
	G	0	0.02	0.86	0	0	0	0	1.00
	H	0.79	0.19	0	0	0.02	0.17	0	0.83
	I	0	0.02	0.90	0	0	0	0	1.00
Max Efficiency	A	0	0	0.22	0	0	0	0	0.16
	B	0	0	0.16	0	0	0.03	0	0.16
	C	0.47	0.45	0	0	0.09	0.41	0	0.55
	D	0	0	0.98	0	0	0	0	0.98
	E	0	0.02	0.88	0	0	0	0	1.00
	F	0	0	0.79	0	0	0	0	0.79
	G	0	0.02	0.88	0	0	0	0	1.00
	H	0.41	0.57	0	0	0.02	0.47	0	0.47
	I	0	0.10	0.79	0	0	0	0	1.00

To perform a removal weakness study, the strategies must be reevaluated without considering any transition arcs that utilize the removed rule. This allows the criticality of that rule to be evaluated for each design of interest. Then, the removal weakness is calculated as the difference in FPS caused by the removal, and can be plotted in a distribution as in Figure 22. Some designs (C,F) have no change, but most have ~2% decrease in efficiency in most epochs, with worst cases approaching -12% for Maximize Utility and -6% for Maximize Efficiency.

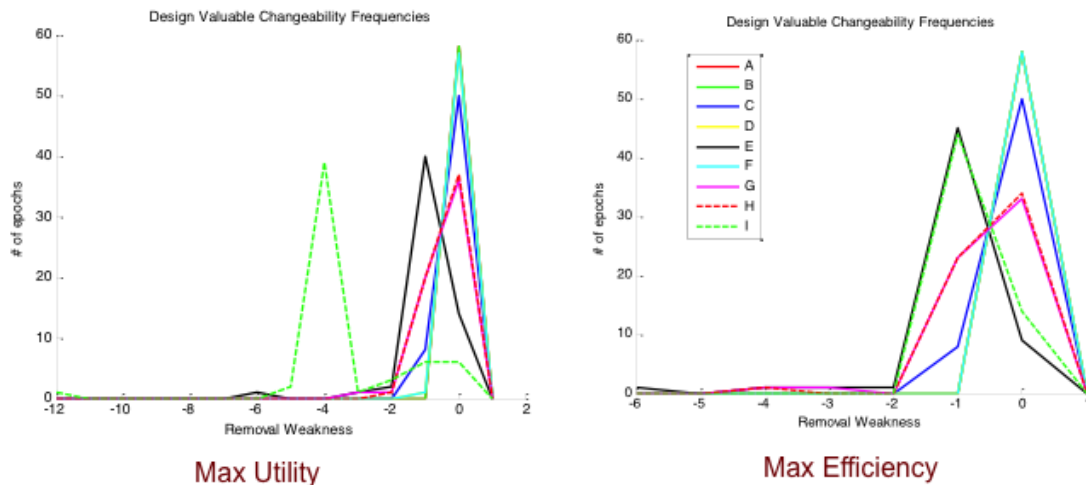

Figure 22. X-TOS - Removal Weakness (FPS Impact of Removing “Redesign”)

Eras can also be re-run with the new strategic transitions to see era-level effects of the removal of redesign. These statistics are shown in Table 15. It is apparent that, while number of transitions and average FPN are about the same, the dollar and time costs of transitions have changed dramatically. Transition time delay has decreased from years to days, as expected from removing the redesign cycle, dramatically increasing the amount of time for which the system is active; this could be very attractive to a stakeholder if this were a revenue-generating project or if utility-months was the lifetime value metric of choice rather than average FPN. However, transition costs have gone up about an order of magnitude as well (this is because the modeling of redesign transition costs does not include the relaunch cost: more careful modeling of that would allow more accurate cost comparisons).

Table 15. X-TOS - Era Statistics (Redesign Removed)

Max Utility					Max Efficiency				
Design	Avg # Trans.	Avg Total Trans Cost	Avg Total Trans Delay	Avg FPN	Design	Avg # Trans.	Avg Total Trans Cost	Avg Total Trans Delay	Avg FPN
A	19.9	\$4.02B	9.5 days	2.71	A	7.4	\$3.59B	8.4 days	1.79
B	19.9	\$4.08B	9.5 days	2.68	B	7.1	\$3.55B	8.2 days	1.96
C	19.8	\$3.97B	11.0 days	5.69	C	10.4	\$4.00B	12.4 days	5.56
D	19.9	\$4.57B	10.8 days	2.86	D	8.2	\$3.92B	9.6 days	2.06
E	19.9	\$4.41B	12.2 days	4.51	E	10.8	\$4.51B	13.9 days	4.57
F	19.8	\$4.50B	10.3 days	2.77	F	8.	\$4.18B	9.5 days	1.97
G	19.8	\$4.51B	12.1 days	4.56	G	10.4	\$4.32B	13.3 days	4.47
H	19.8	\$4.39B	11.6 days	5.55	H	10.6	\$4.25B	12.7 days	5.42
I	19.9	\$4.26B	12.7 days	2.89	I	7.7	\$3.49B	10.0 days	1.99

As a final synthesis, consider that the stakeholder has selected Design B (31) for its combination of high fNPT and high-scoring FPS in the few epochs in which it performs poorly, but is interested in potential tweaks to the design. Looking back at Table 14, it is obvious that B never utilizes a refuel and almost never utilizes the tug feature. If it is possible to isolate and remove these features, this represents a potential means to reduce design costs of Design B. This benefit of reduced costs comes at a penalty of slightly reduced changeability (by removing the few times you would choose to execute a tug) that can be quantified by another removal weakness study. Alternatively, if another potential change mechanism has been deemed feasible (for example, a variable angle sampling scoop), additional modeling could be used to estimate its cost, and it can be inserted into the study to calculate its lifetime performance benefits. Modeling efforts like this can be used to establish a “going rate” for changeability in the system: the cost/benefit tradeoff of adding or removing changeability from the selected design.

Case Outcome. As a result of the experimentation case, the team modified the approach and clarified the steps, as well as refined the metrics. The result was the Valuation Approach for Strategic Changeability (VASC) and supporting metrics, which were subsequently applied to the Space Tug Case and the Satellite Radar Case.

4.1.4.2 Space Tug Case Study

The primary purpose of the application of the Space Tug case in this research investigation was to demonstrate the end-to-end process in a relatively simple case. In particular, the application to the Space Tug system demonstrates both evaluation of valuable changeability within epochs (short run value of changeability) as well as across eras via “strategies” (long run value of changeability).

Background. A space tug is a vehicle designed to rendezvous and dock with a space object; make an assessment of its current position, orientation, and operational status; and, then, either stabilize the object in its current orbit or move the object to a new location with subsequent release. A previous MATE study explored the tradespace for a general-purpose servicing vehicle (McManus and Schuman, 2003). Three attributes formed the multi-attribute utility function: total ΔV capability, capability of the grappling system, and response time (slow or fast). To provide these attributes, three design variables were considered in subsequent modeling activities: manipulator mass, propulsion type, and fuel load. A full-factorial, design space was sampled and analyzed—featuring 128 designs—by inputting each possible combination of design variables from a set of enumerated values over a range into (1) a parametric cost estimation model and (2) a physics-based performance model.

Step 1: Set Up Data for Epoch-Era Analysis

In order to apply the Space Tug dataset for this analysis, the original three design variables were expanded to four design variables, which, when enumerated, resulted in 384 designs. The design variables were:

- Propulsion type (bi-prop, cryo, electric, or nuclear)
- Fuel mass
- Capability level
- Design for changeability (DFC) level

The DFC level is a switch intended to model a conscious effort to design for ease of redesign/change. In the model, it varies from 0 to 1 to 2, with the reward of additional and/or cheaper change mechanisms, and the penalty of additional dry mass, resulting in higher costs and lower available ΔV .

In addition to the design-space, there were 16 epochs considered, generated from 2 contexts and 8 user preference sets. The 2 contexts corresponded to present or future technology level, which affects the transition costs, fuel efficiencies, and mass fractions.

In order to generate the tradespace network for Space Tug, six change mechanisms were defined and are listed in Table 16. Rules 1-5 are “redesign” rules, which require decommissioning and relaunching a space tug (with the associated costs) and rule 6 is an “operations” rule, and does not require a new space tug.

Table 16. Space Tug Study Transition Rules (Change Mechanisms)

#	Rule	Effect	DFC level
1	Engine Swap	Biprop \leftrightarrow cryo	0
2	Fuel Tank Swap	Change propellant mass	0
3	Engine Swap (reduced cost)	Biprop \leftrightarrow cryo	1 or 2
4	Fuel Tank Swap (reduced cost)	Change propellant mass	1 or 2
5	Change capability	Change capability	1 or 2
6	Refuel in orbit	Change propellant mass (no redesign)	2

Once these rules were defined, an automated algorithm determined the accessibility of each design in the tradespace (N=384) to one another via each of the 6 transition rules, along with calculating the transition cost (dollars and time) for each allowed path between two designs. After these transition matrices were calculated, a multi-arc calculation was performed to determine the “non-dominated” paths linking any two designs in the tradespace. The “collapsed” transition matrix lists the most efficient (in terms of cost and time) paths allowed between any two designs in the tradespace. The multi-arc transition matrix is illustrated with a “spyplot” in Figure 23, with each mark indicating allowable transition from row i to column j.

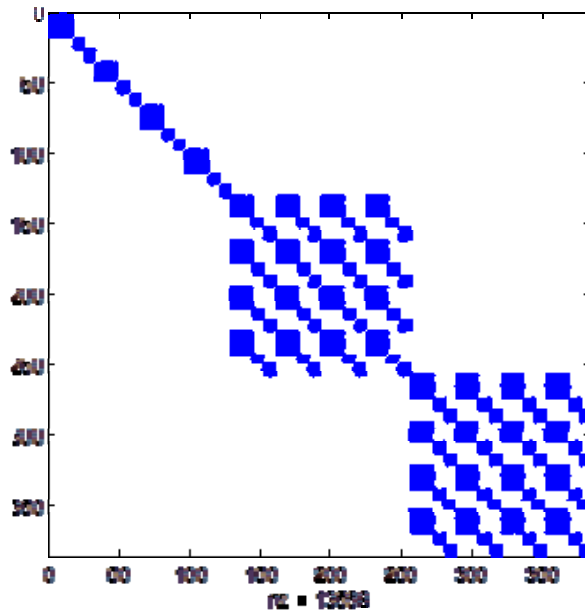

Figure 23. Space Tug Multi-arc Transition Matrix

Step 2: Identify Designs of Interest

After setting up the data for epoch-era analysis, the next step is to identify designs of interest. For purposes of VASC, “interesting” designs are those that have a high likelihood of being valuable over a period of time, such as the intended lifecycle for a system. Two categories of potentially interesting designs include those that are “passively value robust” and those that are highly changeable. The former designs perform well across a number of epochs without needing to change. The latter designs have a large “degree” of change, but it is unknown if the accessible end states are of any value.

In order to identify the “passively value robust” designs, the Normalized Pareto Trace (NPT) and Fuzzy Normalized Pareto Trace (fNPT) can be used, with high scores indicating “interesting” designs for further consideration. NPT can be calculated by counting the fraction of epochs in which a given design appears in the utility-cost Pareto set (Figure 24). fNPT is calculated by allowing the definition of “Pareto set” to include designs within K% of the Pareto Frontier. For this study, the 1% and 15% fuzzy Pareto Frontier was used (Figure 25). In order to identify the highly changeable designs, the Filtered Outdegree (FOD) can be calculated by counting the number of accessible end states available for a given starting design state. The filter is a constraint on the amount of dollars and time (transition cost) willing to be spent in executing a change. As the filter becomes more constraining, the FOD decreases differentially across design alternatives. No filter results in counting all accessible end states, regardless of transition costs, which is the Outdegree (OD) of a design in the tradespace network. For this study, both no filter, and a four month transition time filter were applied (Figure 26).

Identifying designs with high NPT

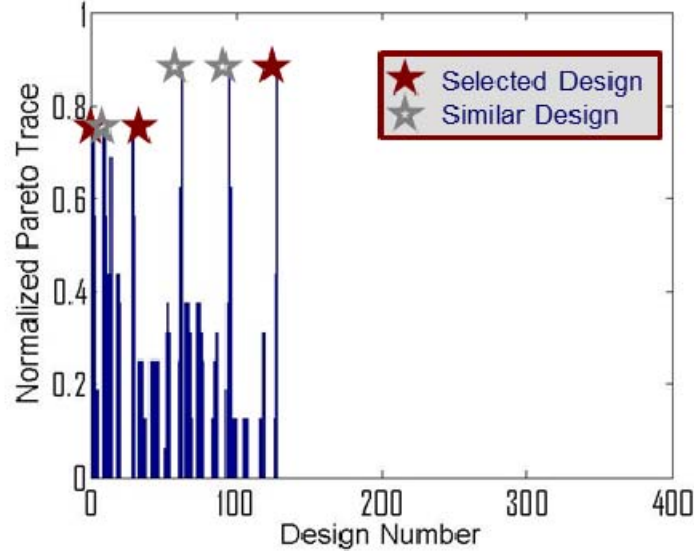

Figure 24. Space Tug Designs with High NPT

Identifying designs with high fNPT

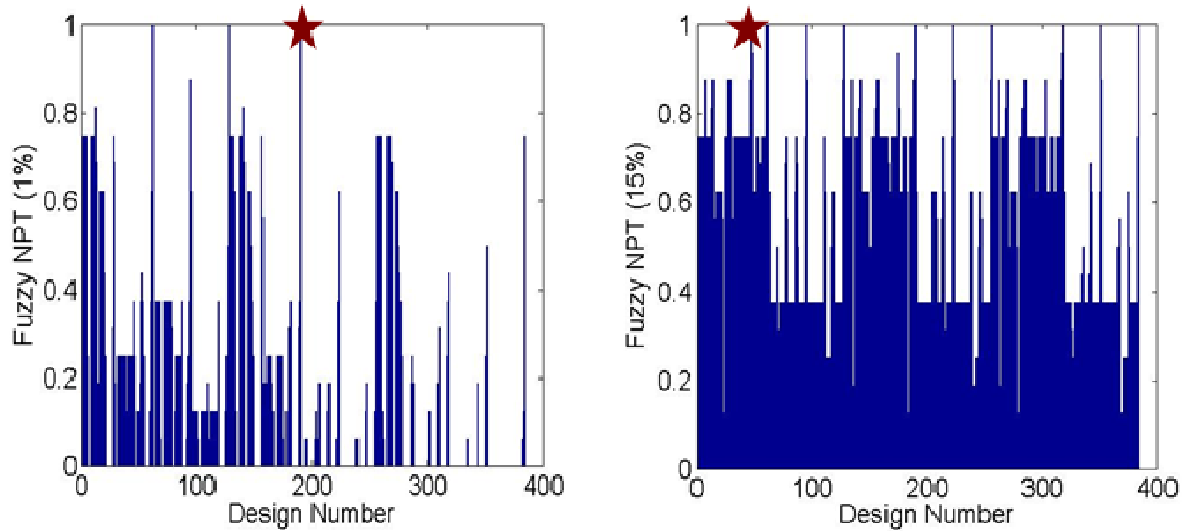

Figure 25. Space Tug Designs with High fNPT

Identifying designs with high FOD

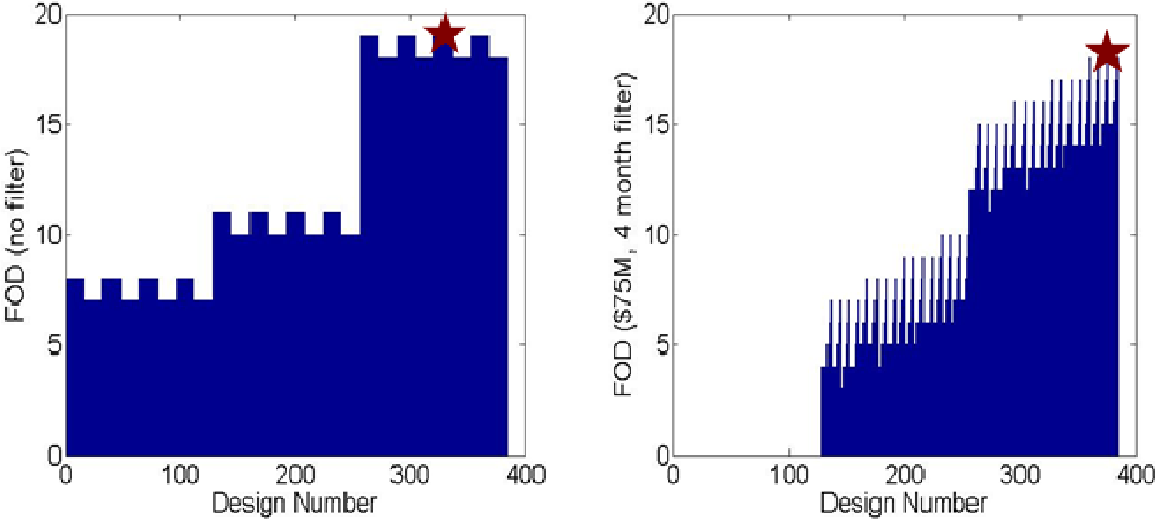

Figure 26. Space Tug Designs with High FOD

The three figures above illustrate the screening metrics across the design space and the indicated chosen designs of interest. Table 17 summarizes the selected designs of interest after applying the screening metrics.

Table 17. Space Tug Designs of Interest

Design Number	Ref	Prop Type	DFC Level	Fuel Mass (kg)	Capability (kg)	Fast?	DeltaV (m/s)	Base Cost (\$M)
1	A	Biprop	0	30	300	Y	143	97
29	B	Nuke	0	1200	300	Y	7381	306
47	C	Cryo	0	10000	1000	Y	6147	628
128	D	Nuke	0	30000	5000	Y	14949	3020
191	E	Nuke	1	10000	1000	Y	16150	980
328	F	Biprop	2	50000	3000	Y	4828	2804
376	G	Elec	2	30000	5000	N	27829	3952

Design variables
Design attributes (present context)

Step 3: Define Rule Usage Strategies

Following the selection of designs of interest, the next step is to define the potential rule usage strategies, which will be used to select the “best” end states for each design/epoch pair. The strategies used in the Space Tug analysis are described below.

Maximize Utility: Make system as good at its job as possible (highest reachable utility per epoch).

Maximize Efficiency: Desire to be as cost-utility efficient as possible.

Survive: Execute change only if system risks becoming “invalid.”

Maximize Profit: (Given a revenue model) use design changes to maximize revenues less costs in each epoch.

Step 4: Conduct Multi-Epoch Changeability Analysis

The next step in the approach is to conduct multi-epoch analysis, that is, conduct analysis across the various potential epochs to see the distribution of valuable changeability across possible alternative future context-needs pairs.

One of the activities in this step is the calculated of the Effective NPT (eNPT) and the Effective Fuzzy NPT (efNPT). These metrics are calculated in a similar to NPT and fNPT, however, instead of only considering the originating design state, this calculation looks at the “best” end state in a given epoch. (Recall that given a strategy, there is one “best” end state in that epoch.)

The “do nothing” strategy is included for comparison and is equivalent to the “robust” design approach, where no change mechanism will be executed. Figure 27 illustrates the impact of strategy on efNPT across the seven designs of interest.

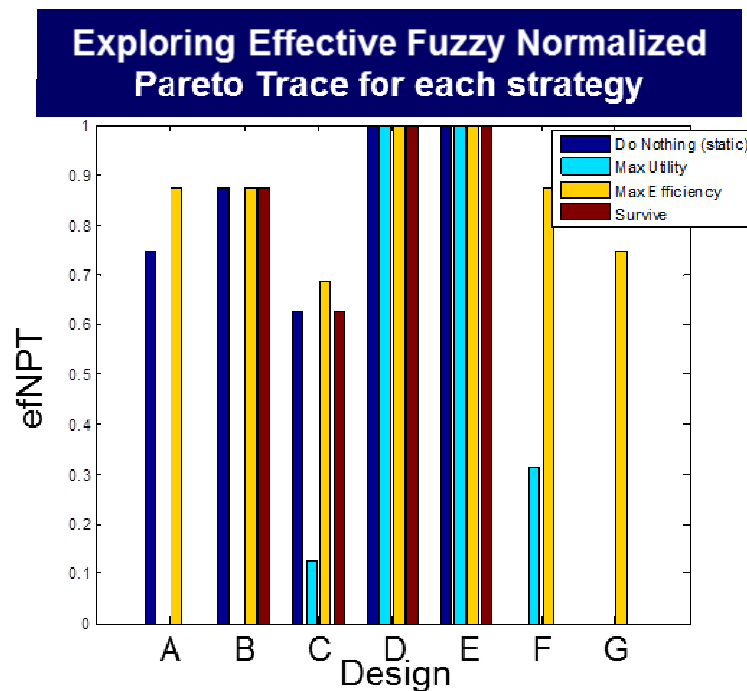

Figure 27. Space Tug efNPT by Strategy for Designs of Interest

Fuzzy Pareto Shift (FPS) can likewise be calculated to see how much the Fuzzy Pareto Number (FPN, a measure of “distance” from the utility-cost Pareto Front in a given epoch) improves by executing a change mechanism. The FPS can range from -100 (move from frontier to most dominated) to 0 (no change) to +100 (move from most dominated to frontier). Failure is recorded as a “-101” meaning the design becomes invalid. “+101” is used to show a design moving from invalid to on the frontier. The FPS can be viewed as a distribution across epochs by strategy, and can be used to compare shapes of the distribution between designs, as well as in a percentile summary table. FPS is calculating the magnitude of the value effects of the “best” design transition in each epoch and can vary significantly between strategies as different rule execution logic and/or restrictions are imposed, changing most desirable end states.

FPS Insights by strategy:

Using the “maximize utility” strategy (Figure 28), designs C, D, E, and F are never invalid when changeability is considered. Maximizing utility generally has a slight negative effect on efficiency, with the exception of design F. Designs D, E, and G do not execute changes in a majority of epochs. Designs A and F have the most effective improvements in efficiency.

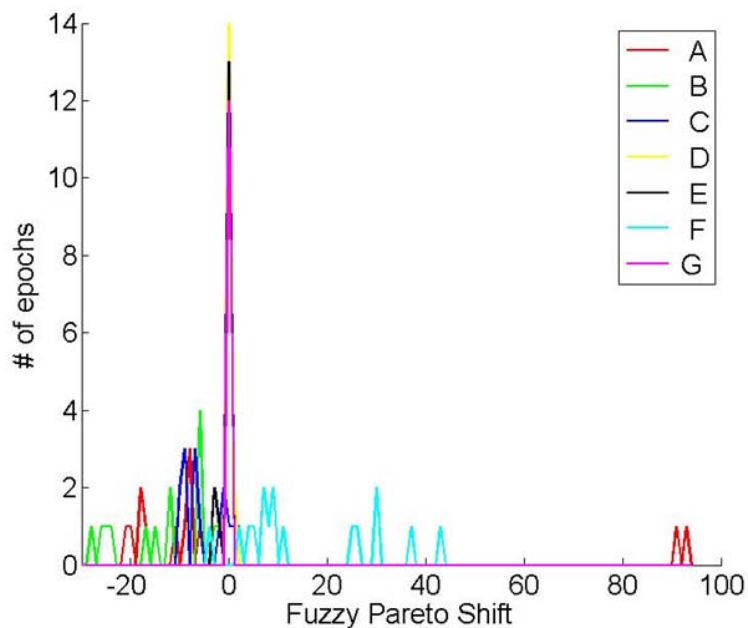

Figure 28. Space Tug FPS Distribution for Maximize Utility Strategy

Using the “maximize efficiency” strategy (Figure 29), one can see that it does not allow for negative FPS changes, excepting unavoidable failure.

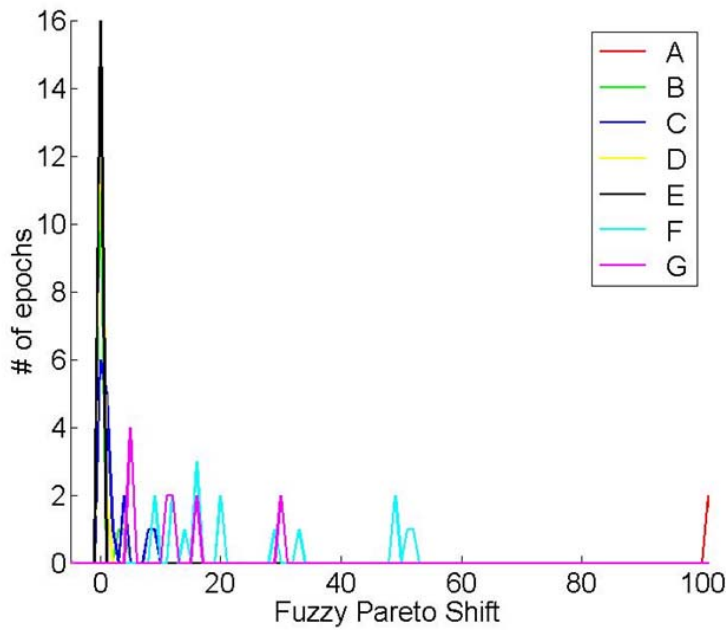

Figure 29. Space Tug FPS Distribution for Maximize Efficiency Strategy

Using the “survive” strategy (Figure 30), one can see that there are many fewer changes, with the exception of design A, which must change always as it will run out of fuel if operated in consecutive epochs.

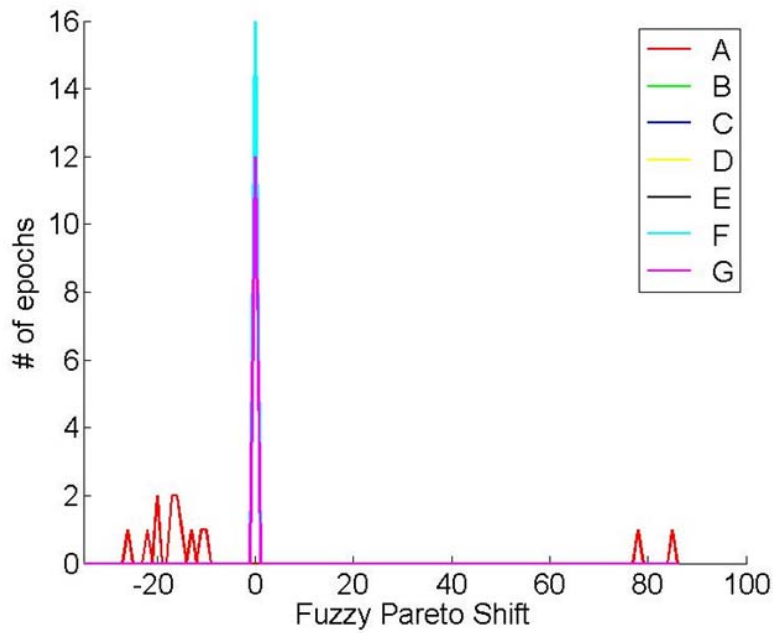

Figure 30. Space Tug FPS Distribution for Survive Strategy

In addition to calculating FPS, Removal Weakness can be performed, which looks at the degree to which a design depends on a particular change mechanism for its valuable changeability. This information is important for assessing the criticality of a change mechanism, showing how valuable a system would be if the mechanism failed. For this system, most of the change mechanisms are redesign types, which doesn't suffer from potential breakdowns. Performing a removal weakness on rule 6 just makes the DFC level 2 designs identical to DFC level 1 designs, but with an additional weight penalty.

One more analysis can be performed looked at the Available Rank Increase which approximates value as the number of designs (ranks) a design can surpass in utility via change mechanisms. This is an imperfect metrics (no accounting for costs and affected heavily by design enumeration), but can be an interesting basis for comparison of change mechanisms as utility enablers.

Figure 31 illustrates the ARI calculation across the design space, comparing rule usage. The take-away is that rules 2, 4, and 6 are used the most in increasing ARI (e.g. utility gain) and these three rules all relate to amount of fuel on-board. This highlights the important utility-enabling characteristic of having more fuel available to the Space Tug.

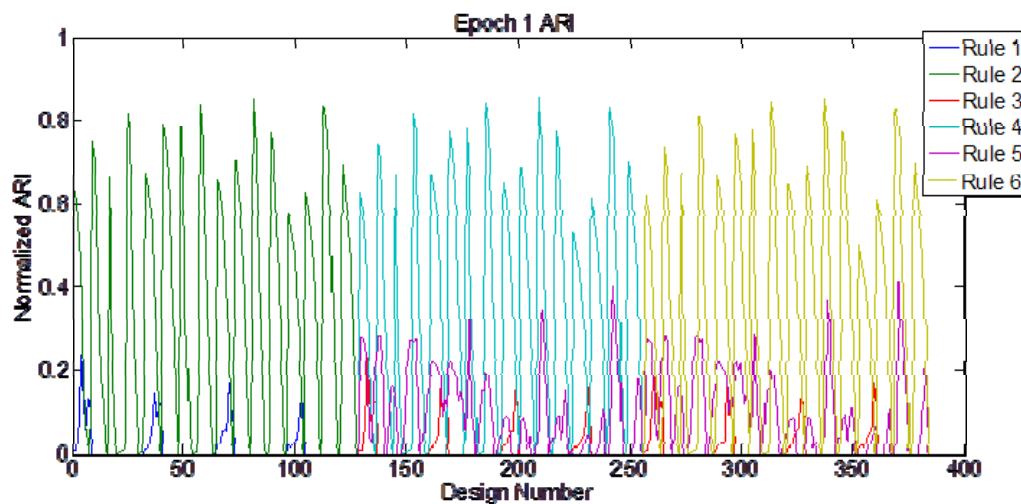

Figure 31. Space Tug ARI Comparison across Change Rules

Step 5: Conduct Era Simulation and Analysis

In the step 5, epochs are time sequenced to determine performance of systems across a lifecycle and can give insights into the path dependence of rule execution and likelihood of using change mechanisms given strategies.

Figure 32 illustrates a roll-up of the Era Analysis for Design E across 5000 potential eras. For these eras, and across the four considered strategies, only rules 4 and 5 were executed. The probabilistic nature of the results is because the rule execution was dependent on the particular era (time-sequenced and duration-labeled epochs) that unfolded. One of the key insights from

step 5 is the ability to generate a “going rate” for changeability against other metrics, such as cost.

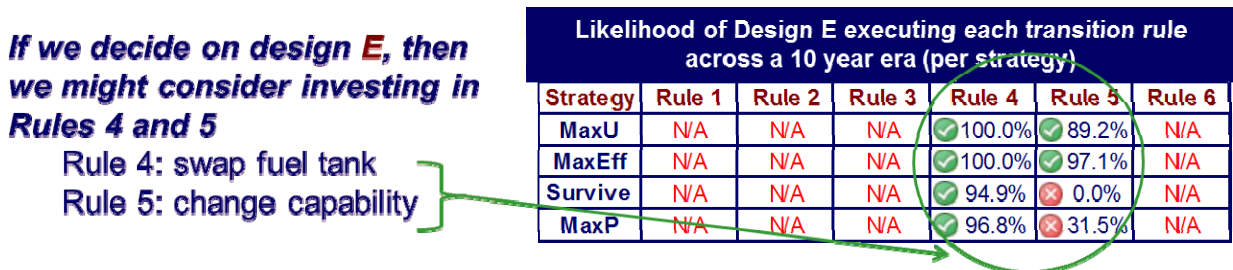

Figure 32. Space Tug Design E Rule Usage by Strategy across a 10 Year Era

As illustrated in Table 18, by comparing designs with and without change mechanisms enabled, one can determine the costs and benefits of adding such changeability across the system lifecycle.

Table 18. Space Tug Changeability Lifecycle Cost/Benefit Tradeoff

-DFC tradeoff	Design	+DFC tradeoff
N/A	D	+\$544M initial cost, +\$34B profit over 10 years
-\$80M initial cost, -\$4B profit over 10 years	E	+\$80M initial cost, +\$21B profit over 10 years
-\$384M initial cost, -\$20B profit over 10 years	F	N/A

4.1.4.3 Satellite Radar Case Study

The primary purpose of the application of the Satellite Radar case in this research investigation was to demonstrate scalability of the end-to-end process in more complex case.

After completing analysis on the X-TOS and Space Tug data sets, the research team began the application of VASC to a Satellite Radar System (SRS). SRS is a satellite constellation designed to provide 24-hour all-weather imaging and tracking of strategic ground targets. The SRS data set is much larger than the previous two, featuring 23,328 designs (from 12 design variables), 972 epochs (from 6 epoch variables), and 8 change mechanisms. In addition to this, the SRS model is designed to track the entire system lifecycle through the Design, Build, Test, and Operations phases, with different expected schedule times for each

design and different change mechanisms available at different costs in each of the phases. Together, these features combine to make for a robust case study, but one that is significantly more challenging to implement in both the multi-epoch and era domains than previous VASC cases.

Although VASC can be a time-consuming process, with the smaller case studies requiring about a day of computation time without including the time for data set creation or multi-arc transition generation, the main restriction for the large case studies is not time, but computer memory. The single-arc transition matrices for SRS (after being collapsed together) take about 20GB of RAM alone, which is more than many workstation class computers are being built with today and certainly too much for older equipment. This was the main barrier for the research team's attempted application of VASC to SRS, as the current MATLAB® implementation of the VASC code base was unable to process such a large amount of data. It is anticipated that further work to optimize the code base to address this limitation would enable the research team to conduct the analysis, however the research period of performance ended before this could be accomplished.

Another barrier to applying VASC to SRS is the newly included considerations of schedule tracking and lifecycle phases. Conceptually, these are not irreconcilable with VASC. Because lifecycle phase determines which change mechanisms are available and how much they cost, the strategies must be applied *to each phase separately* in Step 3. In some sense, this suggests that a multi-phase study in VASC will simply take the form of VASC applied independently to each phase in steps 3 and 4, with the results intelligently combined by the team to draw conclusions. Era analysis remains the same, as modeling a system lifecycle by necessity requires progressing through the phases together (not independently), but demands a more sophisticated era constructor and simulation code. Since each design has an expected duration for each phase, when a transition is executed, the time cost needs to be applied as a delay in schedule and then the new expected duration would be the duration of the end state minus the original duration. Phase changing will occur independently of epoch switches, as soon as the schedule time is reached. In addition to providing a more realistic lifecycle model, the inclusion of phases allows for additional interesting strategies and era-analysis metrics. Because "time to fielding the system" is typically an important design criterion, "minimize expected schedule time" is a potential strategy of interest; additionally total schedule delay (transition cost plus potential extended schedule time of new design) can be used as a threshold, as in "maximize utility without increasing expected schedule time by more than 1 year." Average total time to fielding including all transitions can be an output of era analysis as well.

The research team's inability to apply VASC to SRS is a reflection of the ambitious scope of the research, rather than infeasibility of VASC itself. The team anticipated challenges regarding the scalability and complexity involved in application of VASC to this case, and in attempting to apply VASC, was able to recognize the potential insights that could be generated on such a case, as well as the challenges needed to be overcome in maturing VASC for general applicability. These challenges are further discussed in the Discussion section below.

4.1.5 Publications

During the performance of the contract, one conference publication was published and presented at the 9th Conference on Systems Engineering Research during April 2011 in Los Angeles, CA. The paper "A Method Using Epoch-Era Analysis to Identify Valuable Changeability in System Design," and was authored Matthew Fitzgerald, Adam Ross, and Donna

Rhodes. The paper is available in the proceedings and on the MIT SEAr website (<http://seari.mit.edu>). The research team expects to publish one additional paper in Spring 2012. In addition, a masters thesis related to the project will be forthcoming in May 2011 by graduate student Matthew Fitzgerald, and following publication will be posted on the SEAr website.

4.2 Discussion

4.2.1 Fit of Research Outcomes with Larger META Projects

In an effort to fit the changeability (a.k.a. “metrics for adaptability”) into the larger META project, the research team participated in a metrics workshop at the July PI meeting. During this workshop, a notional figure of META design flow was shared. Figure 33 below indicates where in the META design flow the VASC work positions itself. It is currently envisioned that VASC would be performed as part of the tradespace evaluation step, following tradespace enumeration and model generation in order to evaluate the tradespace. Since VASC requires performance of alternative designs to be evaluated across a number of epochs (context-need pairs), one must have performance models that can generate this data. Additionally, the META tools must add in considerations for change mechanisms and path enablers. This consideration is in addition to the classical design-performance considerations shown implicitly in the design flow picture.

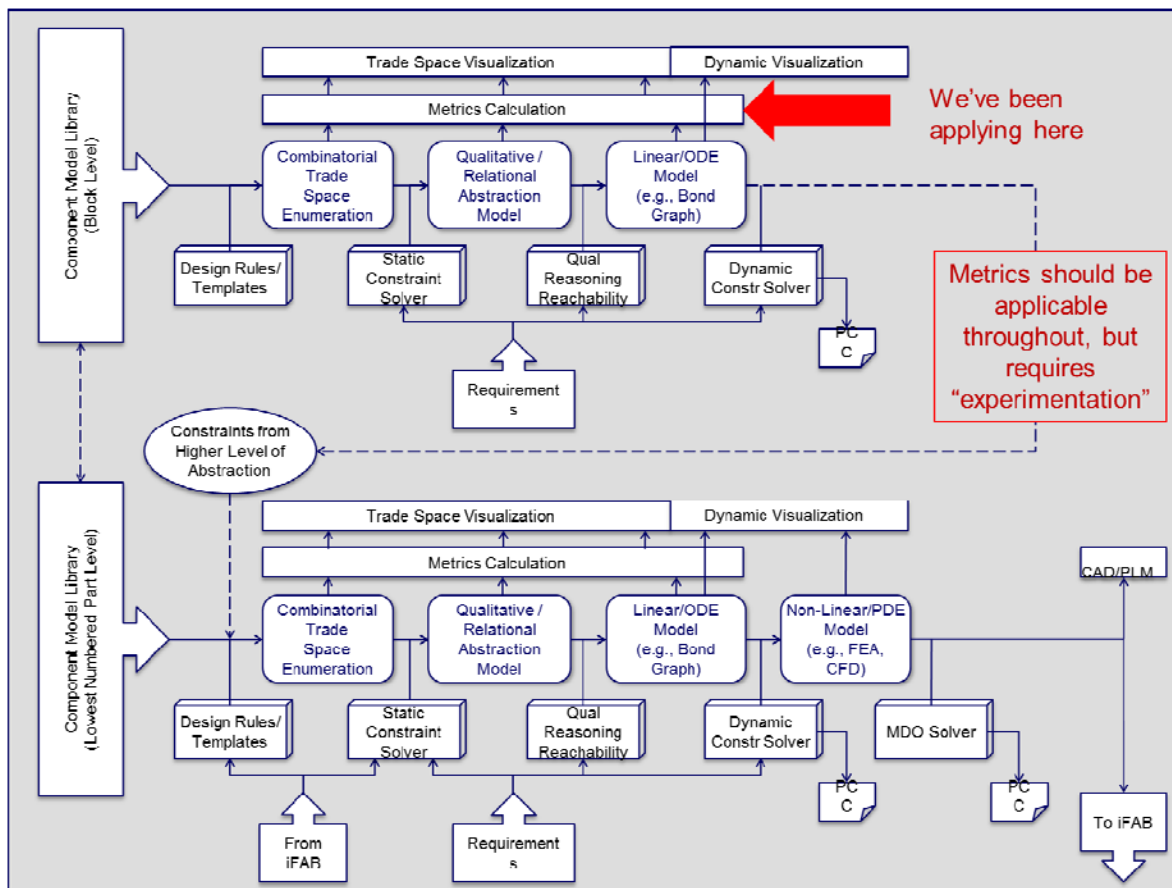

Figure 33. META Design Flow with Changeability Metrics Indicated

4.2.2 Scalability of Approach

As seen in Table 19, the VASC has mostly friendly scaling properties to extremely large projects, with the exception of collapsing multi-arc transitions (“Rule Collapse”), which scales poorly with number of change mechanisms. A simple workaround at this point is to only consider “single-arc transition”, meaning execution of one change mechanism per epoch. The approach is valid, though less informative, when considering such single-arc transitions. It is expected that additional research will be able to uncover appropriate approximations or alternative algorithms that can improve the approximate scaling order of Rule Collapse.

Table 19. Scalability of Activities in VASC

Activity	Worst Variable to Increase	Approximate Order
Epoch Dataset Generation	# model runs/context	Linear, but model runtime is critical
Transition Matrices Generation	# designs	N^2 (worst case, depends on rule algorithm)
Rule Collapse	# change mechanisms	Factorial
FPN	# designs	Linear, but depends on shape of tradespace
NPT (fuzzy, effective)	# designs / epochs	Linear in both
Strategy End State Calculation	# designs	Linear, but time depends on complexity of strategy
FPS	# designs	Simple arithmetic, but depends on having FPN and Strategy calculated
Removal Weakness	# change mechanisms - 1	Requires a repeat of Rule Collapse
Era Simulation	# eras per design / strategy complexity	Linear, but dependent on strategy if some era information is known

An additional concern regarding scalability is the execution time associated with VASC. As little time was spent on code optimization, speeding up current algorithm runtime is certainly possible through additional research. Related to execution time, the research team uncovered a number of programming challenges when attempting to apply VASC to larger data sets, which is described briefly in the following section.

4.2.2.1 Programming Challenges Uncovered in SRS Case Study

The SRS data set is much larger than the other two data sets used in this research, featuring 23,328 designs (from 12 design variables), 972 epochs (from 6 epoch variables), and 8 change mechanisms. VASC is feasible for case studies as large as, or larger than, SRS. What will be key in implementing VASC on such cases is intelligent use of data management and parallelization. MATLAB® stores all of the variables in the workspace in active RAM and, when the amount of data in the workspace nears the maximum limit, all operations begin to slow down exponentially. Ideally, only the data needed at any given time would be in the workspace. Since loading and unloading data from the workspace takes a finite amount of time directly

proportional to the amount of data, there will be some optimal amount of data to be stored and called at a time. For example, during era simulation it is unnecessary to have access to the strategic changes for any design but the current design; a code structure that loads only the relevant changes and swaps them out for the appropriate set whenever the system transitions to another design would minimize memory requirements but require a load/unload of data after every transition. The current method (all data stored as active) maximizes memory requirements and *would* minimize time requirements if not for the slowdown associated with maxing out a computer's RAM. Thus, an optimal point for the time to run VASC lies between these two extremes, loading and unloading small batches of data as they become necessary. The research team at SEArI will be looking into this modification in the near future, but it will likely require an overhaul of much of the existing VASC code base. The research team is optimistic that experienced programmers who seek to mature the VASC code base will be able to make these improvements and overcome limitations inherent in the MATLAB® code base developed in this research task by less experienced student programmers.

The other key potential improvement available to reduce the runtime of VASC is parallelization: tasking multiple computer/processors with different jobs simultaneously to accomplish more work at once. VASC is well suited to parallelization in all of its steps, as the calculations required are mostly independent across designs and epochs. As an example, consider the determination of strategic transitions in Step 3: the logic used to determine if and how a given design will transition in a given epoch is completely independent of all other determinations of the same type, thus allowing the process to be split up amongst any number of available computers with only the small additional cost of eventually combining all of the results together. This is also true for multi-epoch analysis (each design can be evaluated separately) and era analysis (each simulated era is independent of all others). The existing VASC code base is not equipped to handle parallelization right now, but implementing it is a less intrusive change than the active workspace modification from the previous paragraph, as it simply requires specifying which designs/epochs should be evaluated in each script rather than requesting all of them at once. While the active workspace change will allow less powerful computers to perform VASC, the parallelization technique will be more critical in speeding up the total computational time. Because of the high degree of independence between tasks, two computers will do the computations in about half the time and so on, with diminishing returns only appearing once the number of computers exceeds the combinations of designs/epochs or designs/eras in consideration (easily in the millions for even moderately sized studies).

4.2.3 Incorporating into Existing Studies

The following are general guidelines for the types of data needed to evaluate changeability using VASC:

- Data to characterize design alternatives (design variables and attributes=decision criteria that differentiate alternatives, such as performance)
- Clearly defined context variables affecting perceived system value
 - Variables need to differentiate epochs
 - Must affect value in a significant/meaningful way for useful information to exist beyond a single epoch
- Change mechanism with execution cost data
- Requisite information for chosen changeability value metric
 - Value must be able to be calculated for each epoch (e.g. “mission utility)

In order to incorporate VASC into existing studies, one must make the following considerations:

One must have a means for selecting the set of “**designs of interest**” for valuable changeability analysis. In the examples shown in this report, screening metrics were used, however one can use whatever means makes sense for a particular study.

One must also have a means for choosing the **value metric** for what is considered “valuable” about changeability. Depending on the study, this choice may change. For example, for commercial systems, impact on net profit may make sense, while for military systems, impact on net utility may make sense. In VASC, a combination of rule execution strategy and “going rate” captures the long run value definition (e.g. accumulated mission utility vs. cost of investment in the changeability).

One must also have a means for transforming the design performance data set into an **epoch-differentiated data set**. Any form of discrete context separation should work. For example, one can perform sensitivity analysis on the performance model, with each distinct level of the varied parameters representing a different possible future context. This makes particular sense when one is varying the uncertain assumed constants in a model. Other example variations that could be performed to generate epochs include: varying stakeholder preferences (including required performance levels or thresholds), varying uncertain physical parameters (e.g., drag coefficient) or cyclical variables (e.g., solar activity), or varying underlying constants in a Real Options/NPV analysis (e.g., growth spread, volatility, risk free rate, discount rate).

4.2.4 Change Mechanisms Elaborated

One of the principle constructs used in this research is the idea of a “change mechanism,” which is the means by which a system design changes state. Interpretation of what is considered a “design state change” is subject to discussion and must be appropriately defined for the level of analysis considered. In this research, the level of analysis is at the conceptual design level, so a state change was interpreted in terms of changes between alternative designs under consideration. Figure 34 illustrates where the concept of “change mechanism” fits within a larger set of constructs related to design and changeability valuation. The green box indicates the Path Enabler-Change Mechanism pair as a “change option,” that is, by having path enablers, one has the option to execute a change mechanism in order to change the system choice from one state to another. Following change mechanisms, which are implemented in tradespace network analysis as “change rules,” one can begin to perform changeability analysis to assess the “degree” to which a design has changeability (the counting aspect of changeability addressed in this research). Following this, one can perform alternative analysis techniques (such as Real Options Analysis, or Epoch-Era Analysis) in order to determine the “value” of the changeability (the magnitude aspect of changeability addressed in this research).

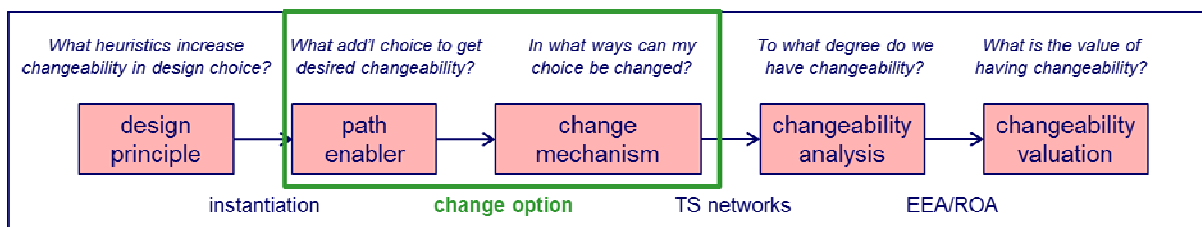

Figure 34. Change Mechanisms as Part of Change Options

In order to help illustrate this set of constructs, Table 20 lists several systems with their path enablers and change mechanisms, along with a rough order of potential end states through the listed change options. Table 21 provides additional change mechanism examples.

Table 20. Examples of Systems, Path Enablers, and Change Mechanism

System	Path Enabler	Change Mechanism	Potential End States
ARAMIS satellite architecture	Modular tile components	Reconfiguring/adding/substituting tiles	Many
iPhone	Mobile App Store and extensible software architecture	Adding new function	Many
Space station w/shuttle	Docking w/ extra fuel and thrusters	Increasing ISS altitude by shuttle firing thrusters	Many
F-14	Mechanical hinged wings	Changing wing sweep angle	Few
Atlas V	Strap-on solid rocket motors	Scaling up or down lift capability	Few
US ISR SoS	Reprogrammable Global Hawk flight-path waypoints	Changing surveillance area, as needed, by combatant commander	Infinite

Table 21. Additional Example Change Mechanisms

System	State Change	Mechanism	Agent
Convertible	Closed-roof to open-roof	Button-activated automatic mechanism	Internal driver
Military Aircraft	Adding external fuel tanks	Universal fittings for tanks/missiles/etc	External crew
V-22 Osprey	Vertical to horizontal flight modes	Rotating mechanism on rotors	Internal pilot
Parachute	Packed to deployed	Pulling release pin to deploy pilot chute	External parachutist
Parachute	Packed to deployed	Explosive activated to pull release pin	Internal emergency AAD pull device
HVAC system	Change temperature	Activating heater or air conditioner	Control thermometer
BMW production plant	Change in car order configuration	Build-your-own vehicle online service	External buyer
BMW production plant	Change between 5, 6, or 7 series production	Similar joining sequences and load carrying points for assembly	Factory management

4.2.5 Considerations for Implementation

One of the benefits of VASC, is that it can accelerate and focus attention on essential aspects of the valuable changeability analysis through targeted software automation. Figure 35

illustrates which parts of VASC require human input, which are software-automated, and which require human interpretation. VASC was intentionally developed in order to leverage automation to the fullest extent possible, and to explicitly highlight when human expert input is required, due to intrinsically subjective aspects of judgment related to definitions of what is considered “valuable.”

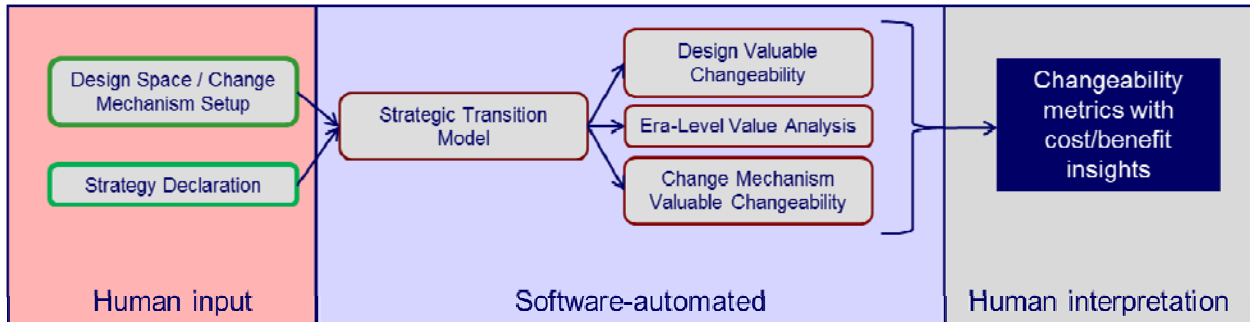

Figure 35. Human vs. Automation in Approach

In VASC, humans must define the following:

- Possible change mechanisms
- “Rules” as algorithmic implementation of mechanisms
- Possible design features that enable change mechanisms (“Path Enablers”)
- Possible rule execution strategies
- Possible epochs (contexts and need pairs encountered by the system)
- Possible design space (system alternatives to be analyzed)

Given these inputs, software conducts much of the analysis, providing a set of changeability metrics and distributions for human interpretation at the end. In particular these metrics seek to give cost and benefit insights into when, where, and why changeability may provide value. The VASC also allows decision makers to construct and compare alternative strategies and design choices that enable short run and long run changeability, in an iterative fashion, promoting up front consideration of changeability as a value-enhancing set of decisions.

4.2.6 Future Research

Future research on VASC will attempt to solve the challenges encountered when applying the approach to the Satellite Radar System (SRS) case study, including scalability of the metric calculation algorithms. Insights from lifecycle-phase dependent analysis will be generated and are anticipated to provide high-level guidance into investment in path enablers as a function of desired lifecycle phase characteristics. In particular, the ultimate aim of “adaptability” as inferred from the DARPA META program is being able to respond to a perturbation on appropriate timescales. This means that changeability should “match” response time in the system to the perturbations encountered by the system throughout its lifecycle. Change mechanisms that act within particular lifecycle phases will have more or less importance relative to particular perturbations. Executed change mechanisms may also send a system

backwards in the lifecycle if such changes result in a need to “re-test” or even “rebuild” the system (see Figure 36). Future work will consider this lifecycle aspect explicitly and seek to build analysis and guidance on which mechanism to invest based on expected (and possible unexpected) perturbations types. The farther a change goes back into the lifecycle, the longer (usually) it takes before utility is experienced again. Choices can be made to give an option to change later in the lifecycle, or to reduce the time and cost for getting back to operations. In this way, changeability can be embedded in a manufacturing capability (e.g., DARPA iFab) or in the system itself. VASC will seek to enable the comparison of tradeoff of both of these types of changeability within a common framework.

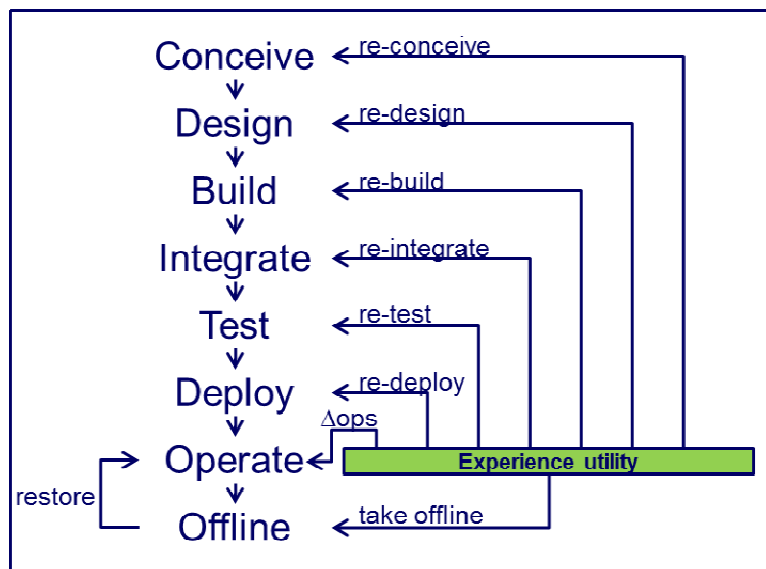

Figure 36. Delay in Experienced Utility as a Function of Change Mechanism- Lifecycle Phase

5. CONCLUSIONS

The primary goal for the research was to uncover difficult to extract information on valuable changeability for a design space and present it in an accessible way to assist in decision making. Other important goals included identifying designs which deliver high amounts of value in different ways (e.g. robustness and changeability), and the operational strategies that maximize value. The research also enabled the assessment of what change mechanisms deliver the most value or are the most critical for some designs to continue to deliver value over time. Ultimately, in order to help to justify the investment in changeability, which has been difficult to do in the past due to asymmetry in ease of identifying costs over benefits, the research has demonstrated a first effort in being able to establish a cost vs. benefit tradeoff for adding or removing changeability from a design (a.k.a. the “going rate” for changeability).

In order to organize and assist analysts and decision makers in capturing changeability tradeoffs within a study, the Valuation Approach for Strategic Changeability (VASC) was developed. VASC is a five step approach that guides analysts through generation and organization of design data, as well as application of analysis to generate valuable changeability metrics and their interpretation. Figure 37 shows the high level flow of data in order to generate the changeability metrics developed in this research.

Figure 37. Data Flow for VASC Metrics

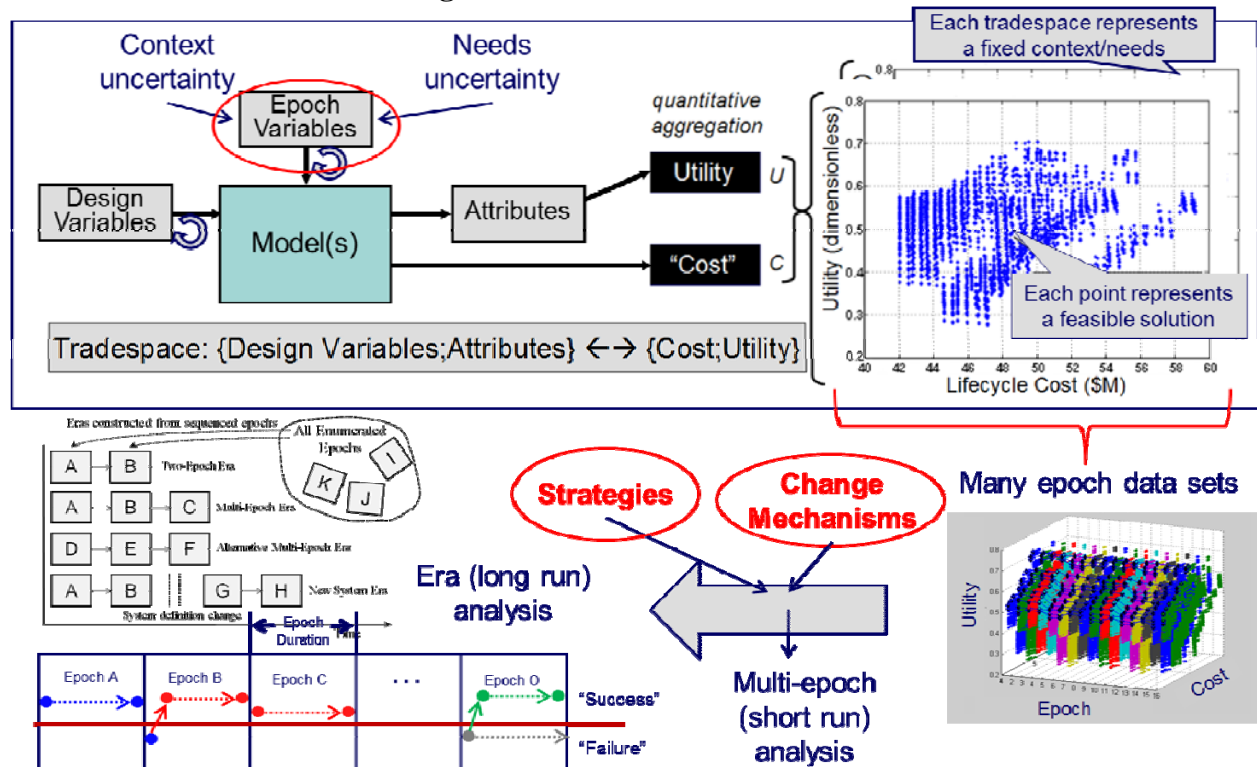

5.1 Research Contributions

In addition to developing the Valuation Approach for Strategic Changeability (VASC), the contributions of this research include:

- Expanded set of screening and valuation metrics (eNPT, efNPT, FPN, FPS) in Table 22
- Explicit method for accounting for value of changeability over short and long time scales (strategy-interpreted)
- Linked explicit design decisions with changeability (change rule comparison)
- Incremental analysis approach that can scale with available information and effort
- An approach that is mostly automated, but also encourages focused value-elicitation and interpretation discussions between decision makers and analysts

Table 22. Final Set of Valuable Changeability Metrics

Aspect of Valuable Changeability	Acronym	Stands For	Definition
Robustness via “no change”	NPT	Normalized Pareto Trace	% epochs for which design is Pareto efficient in utility/cost
Robustness via “no change”	fNPT	Fuzzy Normalized Pareto Trace	Above, with margin from Pareto front allowed
Robustness via “change”	eNPT, efNPT	Effective (Fuzzy) Normalized Pareto Trace	Above, considering the design’s end state after transitioning
“Value” gap	FPN	Fuzzy Pareto Number	% margin needed to include design in the fuzzy Pareto front
“Value” of a change	FPS	Fuzzy Pareto Shift	Difference in FPN before and after transition
“Value” of a change	ARI	Available Rank Increase	# of designs able to be passed in utility via best possible change
Degree of changeability	OD	Outdegree	# outgoing transition arcs from a design
Degree of changeability	FOD	Filtered Outdegree	Above, considering only arcs below a chosen cost threshold

6. REFERENCES

1. Warwick, G., "DARPA Wants to Break the System Mold," *Aviation Week*, August 3, 2010
2. Ross, A.M., "Managing Unarticulated Value: Changeability in Multi-Attribute Tradespace Exploration," PhD thesis, MIT, June 2006
3. Fricke, E. and Schulz, A.P., "Design for Changeability (DfC): Principles to Enable Changes in Systems Throughout Their Entire Lifecycle," *Systems Engineering*, Vol. 8, No. 4, 342-359, 2005.
4. McManus, H. and Hastings, D.E., "A Framework for Understanding Uncertainty and Its Mitigation and Exploitation in Complex Systems," *IEEE Engineering Management Review*, Vol. 34, No. 3, pp. 81-94, Third Quarter 2006.
5. Fricke, E., Gebhard, B., Negele, H., and Igenbergs, E., "Coping with Changes: Causes, Findings, and Strategies," *Systems Engineering*, Vol. 3, No. 4, 169-179, 2000.
6. Fricke, E., and Schulz, A.P., "Design for changeability (DfC): Principles to enable changes in systems throughout their entire lifecycle," *Systems Engineering*, vol. 8, 2005, pp. 342-359
7. Ross, A.M., Rhodes, D.H., and Hastings, D.E., "Defining Changeability: Reconciling Flexibility, Adaptability, Scalability, Modifiability, and Robustness for Maintaining Lifecycle Value," *Systems Engineering*, Vol. 11, No. 3, pp. 246-262, Fall 2008.
8. Chen, W. and Yuan, C., "A Probabilistic Design Model for Achieving Flexibility in Design," *ASME Journal of Mechanical Design*, Vol. 120, No. 9, 1998.
9. Rajan, P.K.P., van Wie, M., Campbell, M.I., Wood, K.L., and Otto, K.N., "An Empirical Foundation for Product Flexibility," *Design Studies*, Vol. 26, No. 4, 405-438, 2005.
10. Keese, D., Tilstra, A., Seepersad, C.C.C., and Wood, K.L., "Empirically-Derived Principles for Designing Products with Flexibility for Future Evolution," 2007 ASME International Design Engineering Technical Conference, Las Vegas, NV, September 2007.
11. Nilchiani, R. and Hastings, D.E., "Measuring the Value of Flexibility in Space Systems: A Six Element Framework," *Systems Engineering*, Vol. 10, No. 1, 2007.
12. Shah, N.B., Viscito, L., Wilds, J.M., Ross, A.M., and Hastings, D.E., "Quantifying Flexibility for Architecting Changeable Systems," 6th Conference on Systems Engineering Research, Los Angeles, CA, April 2008.
13. Ross, A.M., "Managing Unarticulated Value: Changeability in Multi-Attribute Tradespace Exploration," MIT Engineering Systems Division PhD thesis, 2006.
14. Ross, A.M., and Rhodes, D.H., "Using Natural Value-centric Time Scales for Conceptualizing System Timelines through Epoch-Era Analysis," INCOSE International Symposium 2008, Utrecht, the Netherlands, June 2008.
15. Viscito, L., and Ross, A.M., "Quantifying Flexibility in Tradespace Exploration : Value Weighted Filtered Outdegree," AIAA Space 2009, 2009, pp. 1-9.
16. Ross, A.M., D.H. Rhodes, and D.E. Hastings, "Defining Changeability : Reconciling Flexibility , Adaptability , Scalability , Modifiability , and Robustness for Maintaining System Lifecycle Value," *Systems Engineering*, Vol. 11, No. 3, pp. 246-262, 2008
17. Ross, A.M., and Hastings, D.E., "Assessing Changeability in Aerospace Systems Architecting and Design Using Dynamic Multi-Attribute Tradespace Exploration," AIAA Space 2006, San Jose, CA, September 2006.

18. Myers, S.C., "Finance theory and financial strategy," *Interfaces*, 14(1), pp. 126-137, 1984.
19. Ross, A.M., Rhodes, D.H., and Hastings, D.E., "Defining Changeability: Reconciling Flexibility, Adaptability, Scalability, Modifiability, and Robustness for Maintaining Lifecycle Value," *Systems Engineering*, Vol. 11, No. 3, pp. 246-262, Fall 2008
20. Trigeorgis, L., *Real Options: Managerial Flexibility and Strategy in Resource Allocation*, MIT Press, 1998.
21. Copeland, T. and Antikarov, V., *Real Options: A Practitioner's Guide*. Texere, 2001.
22. de Neufville, R., "Real options: Dealing with uncertainty in systems planning and design," *Integrated Assessment*, 4(1):26-34, 2003
23. de Weck, O., de Neufville, R. and Chaize, M., "Staged deployment of communication satellite constellation in low earth orbit," *Journal of Aerospace Computing, Information, and Communications*, 1(3):119{131, 2004.
24. Wang, T. and de Neufville, R., "Identification of Real Options 'In' Projects," 4th Conference on Systems Engineering Research, Los Angeles, CA, April 2006.
25. Black, F. and Scholes, M., "The pricing of options and corporate liabilities," *Journal of Political Economy*, 81:637-654, 1973.
26. Cox, J., Ross, S., and Rubinstein, M., "Option pricing: A simplified approach," *Journal of Financial Economics*, 7:229-263, 1979.
27. Boyle, P., "Options: A Monte Carlo approach," *Journal of Financial Economics*, 4:323-338, 1977.
28. Mikaelian, T, Rhodes, D.H., Nightingale, D.J., and Hastings, D.E., "Managing Uncertainty in Socio-Technical Enterprises using a Real Options Framework," 6th Conference on Systems Engineering Research, Los Angeles, CA, April 2008.
29. McManus, H., and Schuman, T., "Understanding the Orbital Transfer Vehicle Trade Space," AIAA Space 2003, Long Beach, CA, September 2003.

APPENDIX A – Publications and Presentations

The publications generated in this research are available on the SEARi website:

Fitzgerald, M.E., Ross, A.M., and Rhodes, D.H., "A Method Using Epoch-Era Analysis to Identify Valuable Changeability in System Design," 9th Conference on Systems Engineering Research, Los Angeles, CA, April 2011.

http://seari.mit.edu/documents/preprints/FITZGERALD_CSER11.pdf

Presentations are available on the DARPA META Sharepoint site.

LIST OF SYMBOLS, ABBREVIATIONS, AND ACRONYMS

Organization

ESD	Engineering Systems Division
SEArI	Systems Engineering Advancement Research Initiative

Projects

A-TOS	A-iteration Terrestrial Observer Swarm
B-TOS	B-iteration Terrestrial Observer Swarm
C-TOS	C-iteration Terrestrial Observer Satellite
X-TOS	X-iteration Terrestrial Observer System
SR	Satellite Radar
TPF	Terrestrial Planet Finder

Process/Methods

DFC	Design for Changeability
EEA	Epoch-Era Analysis
MATE	Multi-Attribute Tradespace Exploration
MAUA	Multi-Attribute Utility Analysis
MAUF	Multi-Attribute Utility Function
VASC	Valuation Approach for Strategic Changeability

Metrics

ARI	Available Rank Increase
eNPT	Effective Normalized Pareto Trace
efNPT	Effective Fuzzy Normalized Pareto Trace
fNPT	Fuzzy Normalized Pareto Trace
FOD	Filtered Outdegree
FPN	Fuzzy Pareto Number
FPS	Fuzzy Pareto Shift
NPT	Normalized Pareto Trace
OD	Outdegree

Variables

DM	Decision Maker
DV	Design Variable
MOE	Measure of Effectiveness
TPM	Technical Performance Measure
X	Attribute
U	Utility

GLOSSARY OF TERMINOLOGY

Adaptability (DARPA): the ability of a system to change easily, quickly, and inexpensively (i.e., with minimum incurrance of cost and degradation in performance) in response to a wide spectrum of anticipated and unanticipated perturbation events exogenous or endogenous to the system.

Adaptability (MIT SEArI): ability of a system to be changed by a system-internal change agent with intent

Changeability: ability of a system to alter its form or operations, and consequently possibly its function, at an acceptable level of resources

Change Mechanism. A method by which the system is changed. An example: “Burn on board fuel” results in change in satellite orbit, costing “extra ops cost” for executing the maneuver (system “state” includes operating orbit).

Change Rule. An algorithm that determines whether two proposed “states” are connected through a particular change mechanism. An example: “Compare two ‘states’ and if difference is only fuel and orbit location, then if fuel difference is equal to amount burned to achieve orbit difference, then states have directed accessibility via change mechanism for cost determined by that mechanism. The change rule is an operationalization of the concept of change mechanism in order to allow for computationally generated and evaluated alternative “paths”

Epoch: An Epoch is a period for which the system context has constant value expectations. Each fixed context is characterized by static constraints, available design concepts, available technology, and articulated attributes

Era: An time-ordered sequence of epochs.

Filtered Outdegree. The number of outgoing arcs (change paths) from one design at acceptable “cost” as a measure of changeability.

Flexibility (MIT SEArI): ability of a system to be changed by a system-external change agent with intent

Pareto Set: characterizes those “non-dominated” designs of highest utility at a given cost, across all costs, or those of lowest cost at a given utility, across all utilities

Real Option: A “real option” gives the decision maker the right, but not the obligation, to exercise an action or decision at a later point in time.

Tradespace Network: a tradespace represented as a network, where the nodes are designs and the arcs are transition paths from one design to another.