

# A Logical Framework for Self-Optimizing Networked Cyber-Physical Systems

Stehr, Mark-Oliver

NEXT:

Sahai

Krishna

# A Logical Framework for Self-Optimizing Networked Cyber-Physical Systems (NCPS)



Mark-Oliver Stehr (PI), Minyoung Kim (Postdoc), Carolyn Talcott (coPI)

## Challenges and Trends

- NCPS consist of increasingly large numbers of heterogeneous components
- Often deployed in challenging environments with intermittent connectivity
- High diversity, many point solutions, but lack of unifying models/frameworks
- Need to operate in the entire spectrum between **autonomy and cooperation**
- Highly concurrent and decentralized NCPS promise robustness, but need approaches to manage system as a single asset, ideally reducing the need for error-prone programming
- Declarative approaches are becoming increasingly used in networking, but logics are traditionally closed, non-interactive, and not suitable for distributed reasoning

## Approach and Contributions

- Partially ordered knowledge-sharing model for **loosely-coupled distributed computing**
- Implemented in new application framework for NCPS
- Distributed logic for declarative control
- First steps towards distributed dynamic optimization
- Simulation case study: Collaborating teams of mobile robots

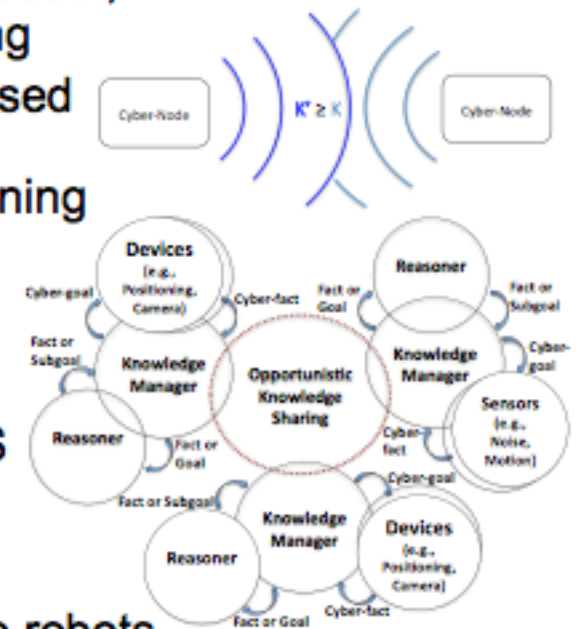

# Collaborative Research: The Foundations of Implicit and Explicit Communication in Cyberphysical Systems

Sahai, Anant; Saligrama, Venkatesh

NEXT:

Krishna

Ganapathy

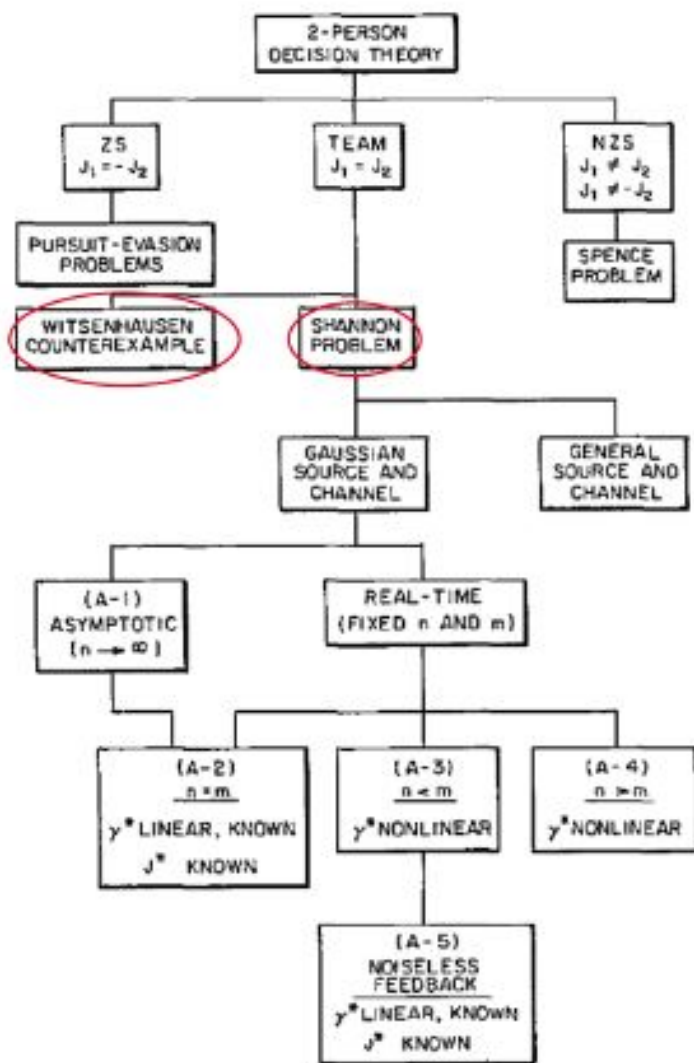
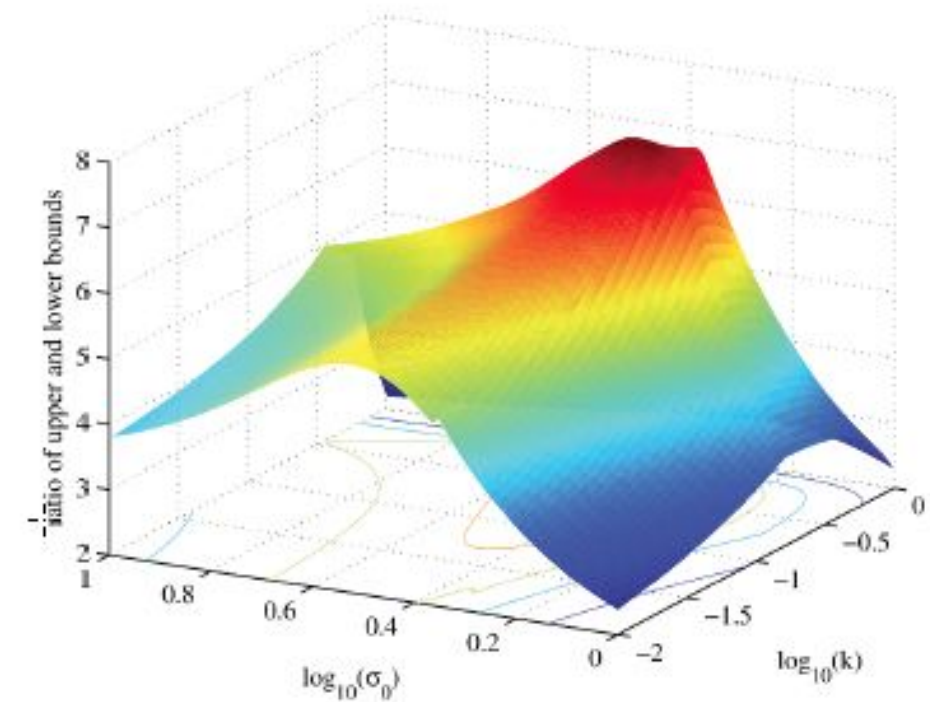
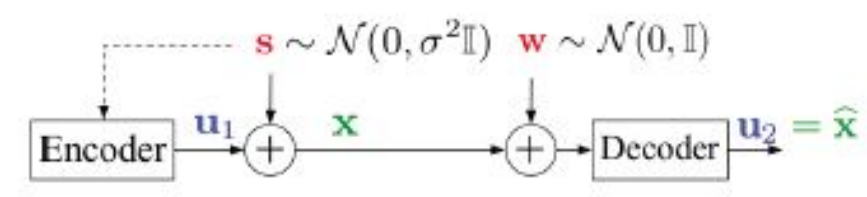
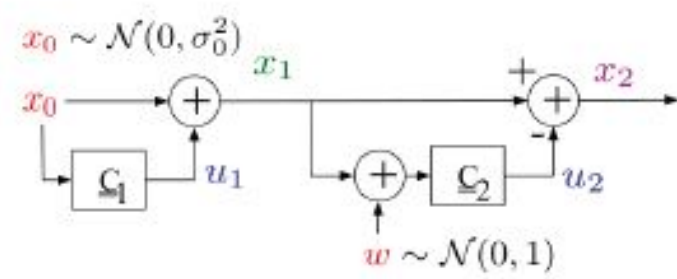

Fig. 1. Teams, signaling, and information theory.  
Ho, Kastner, and Wong





# Collaborative Research: Abstraction of Cyber-Physical Interplays and Its Application to CPS Design

Krishna, C.Mani; Shin, Kang; Koren,  
Israel

NEXT:

Ganapathy

Myers

# Abstraction of Cyber-Physical Interplays and Its Application to CPS Design

K. G. Shin, E. M. Atkins (Michigan); I. Koren, C. M. Krishna (UMass)

- **Plant-to-Computer Interface:**  
Specifies how the application's QoS degrades as a function of:
  - Current application and environmental state
  - Computational delays
  - Computational imprecision
  - Residual mission lifetime
- **Computer-to-Plant Interface:**  
Specifies
  - Task periods, precision levels, and priority rules
  - Use of energy reserves
  - Task milestones completion
  - Computational health

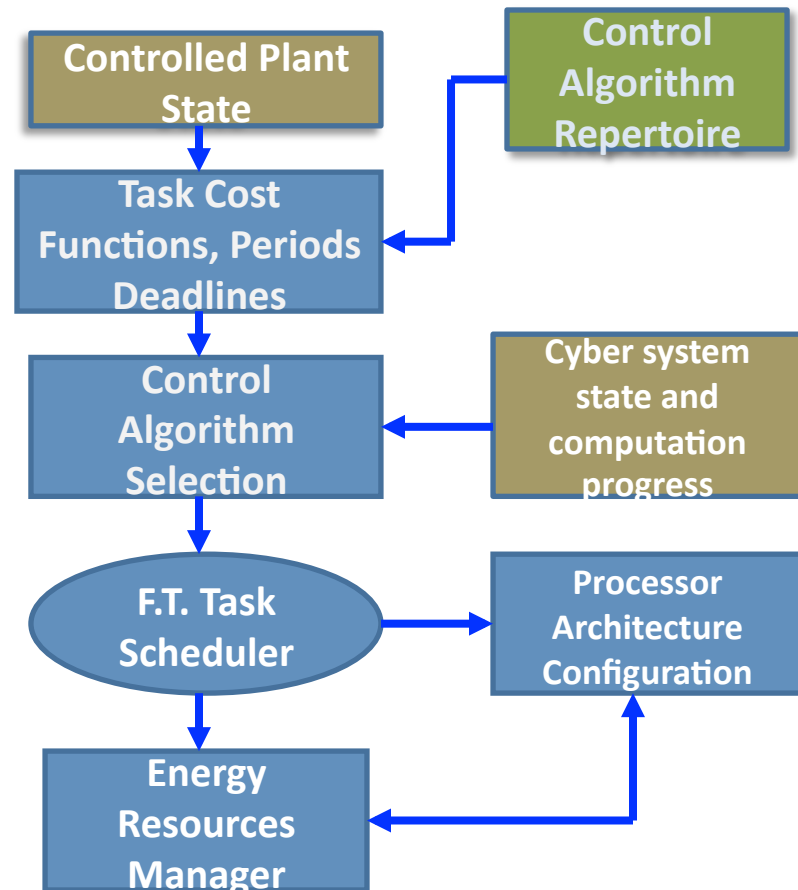

# Collaborative Research: Establishing Integrity in Dynamic Networks of Cyber Physical Devices

Ganapathy, Vinod; Jaeger, Trent;  
Kremer, Ulrich

NEXT:

Myers

Krause

# Establishing trust in cyber-physical computing

- **Scenario:** Dynamic networks of cyber-physical devices to allow opportunistic and participatory sensing applications (SARANA)
  - Allow a device to ship code to other devices for execution
  - Economic incentives may be involved for performing computation
- **Question:** How to bootstrap trust in such settings?
- **Answer:** Trusted computing: Cryptographic hardware (TPMs) on devices allow trust establishment.
- **Problem:** Existing trusted computing protocols are not designed for resource-constrained cyber-physical settings.
  - Interactive in nature, require storage to check/verify integrity measurements.
- **Our project:** We are investigating the energy impact of trusted computing protocols and are devising new ones suited for cyber-physical settings

# Collaborative Research: Methods and Tools for the Verification of Cyber-Physical Systems

Myers, Chris; Zheng, Hao

NEXT:

Krause

Platzer

# Methods and Tools for Verification of CPS

- CPS include complex computing and networking architectures.
- An example is the *network-on-chip* of *embedded control units* for automobiles being designed by Yoneda et al. w/support from Toyota.

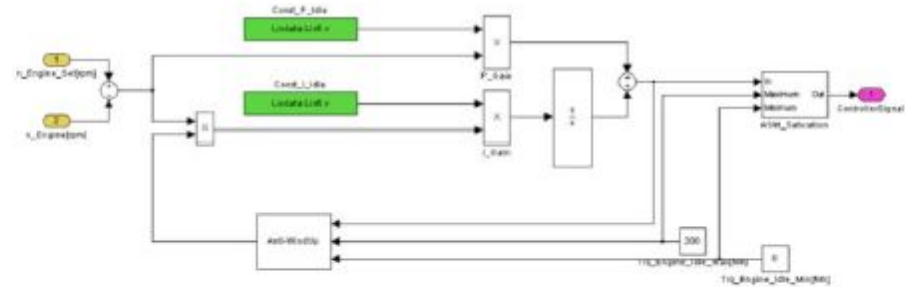
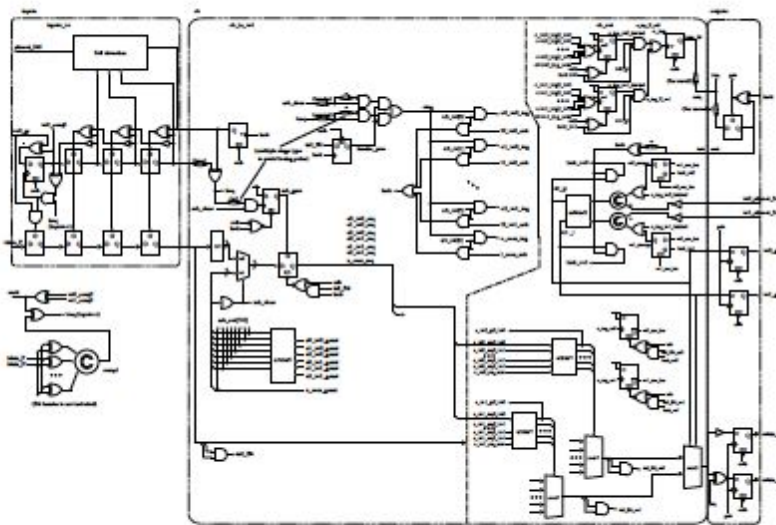

- Requires integrated modeling formalism that includes both discrete/continuous signals updated synchronously/asynchronously.
- Must verify functional and timing correctness as well as fault tolerance in the face of both hard and soft errors.
- Abstraction and compositional reasoning key to achieve scalability.



# Community-based Sense & Respond -- Theory and Applications

Krause, Andreas

NEXT:

Platzer

Lafortune



# Community Sense & Respond

Krause, Chandy, Clayton, Heaton

@caltech

..where theory and practice collide

How can we build community-held CPS that allow sensing and responding to crises?

Sense:  
Cascading failures,  
traffic jams,  
earthquakes

Respond:  
Regulate grid, traffic,  
stop trains, elevators

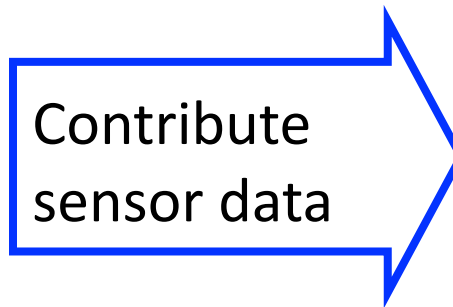

Community  
Seismic Network

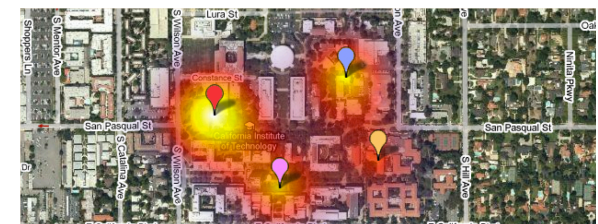

USB accel., Android phones  
Google AppEngine

CPS Challenges

Uncertainty  
Continuous/discrete  
Safety-critical  
Scale

Our Approach

Robust Bayesian reasoning  
Distributed anomaly detection  
No-regret online learning  
Cloud computing

# Compositionality and Reconfiguration for Distributed Hybrid Systems

Platzer, Andre

NEXT:

Lafortune

Christofides

# Compositionality and Reconfiguration for Distributed Hybrid Systems

André Platzer, Edmund M. Clarke, Sarah M. Loos  
Carnegie Mellon University

## Hierarchical Modularity

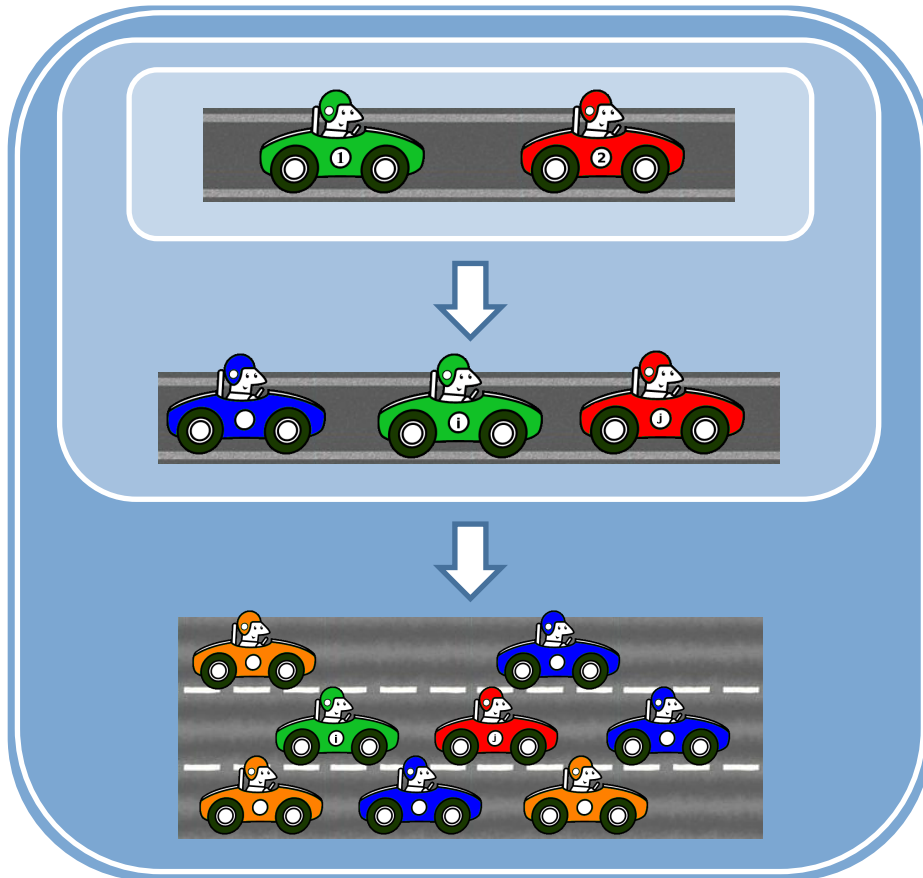

## Nonlinear Dynamics

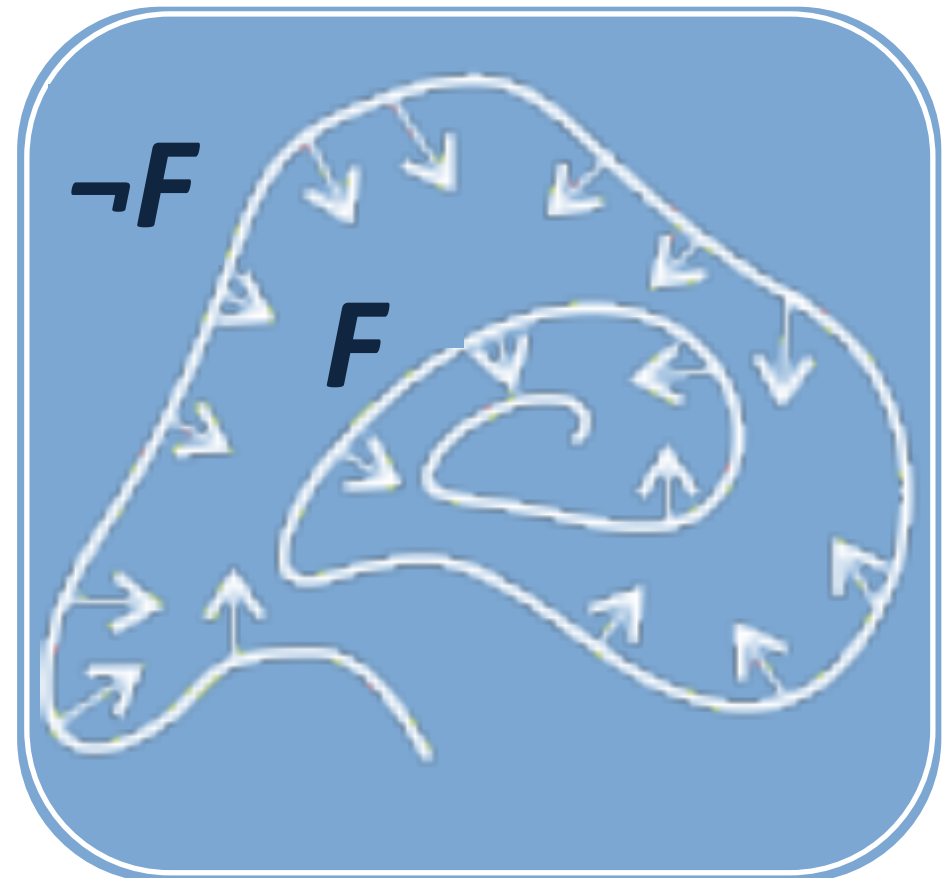

# Control of Distributed Cyber-Physical Systems under Partial Information and Limited Communication

Lafortune, Stephane

NEXT:

Christofides

Chopra

# CPS - Small: Control of Distributed CPS under Partial Information and Limited Communication

Stéphane Lafortune (EECS, Michigan) and Domitilla Del Vecchio (ME, MIT)

## Theoretical Approach:

- *Safety and Liveness* specifications considered
- Coupling of *Discrete-Event* (DE) solver with *Hybrid* solver
- Lift *informational* issues at DE level
- *Optimize* at Hybrid level
- Linking concepts: *Observers, Information State, Automata*

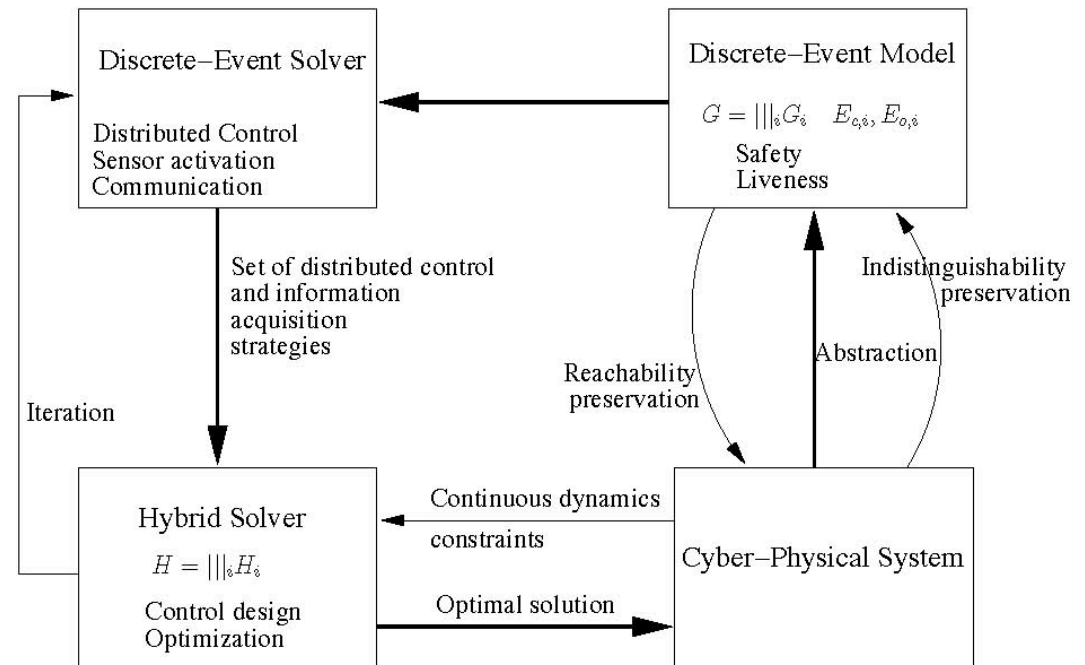
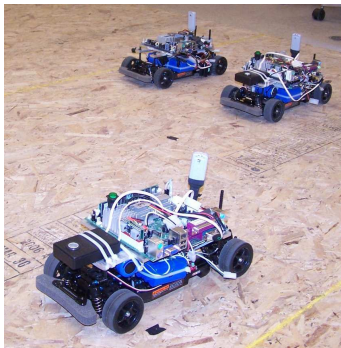

Figure 1: Integrated Hybrid/Discrete Solution Procedure

## Cooperative Active Safety in ITS:

- Experimental test-bed (Del Vecchio's Lab at MIT)
- Collision avoidance scenarios (e.g., roundabout): capture set
- Limited sensing and communication; semi-autonomous



# Design of Networked Control Systems for Chemical Processes

Christofides, Panagiotis

NEXT:

Chopra

Kuipers

Motivation and Objective

- Chemical and petrochemical industry is a major sector of the US and global economy
- Process control and monitoring systems traditionally utilize point-to-point links to sensors and actuators
- Networked control and monitoring (wired/wireless) could be employed to improve plant performance and effectively handle, potentially catastrophic, failures
- Project objective:
  - To develop the theory and methods needed for the design and monitoring of networked control systems for chemical processes that utilize sensor and actuator networks

Networked Control System Design

- Centralized networked control
  - Augmentation of existing, dedicated control systems with centralized networked control systems
  - Lyapunov-based model predictive control
  - Provable stability, performance and robustness
- Distributed networked control
  - Design of cooperative, distributed controllers
  - Network communication architecture design
  - Handling asynchronous/delayed sampling and communication disruptions

Networked Monitoring and Fault-Tolerant Control

- Fault monitoring, diagnosis and handling
  - Design of fault detection and isolation filters uniting model-based and data-based approaches
  - Fault-tolerant control: automatic controller reconfiguration to minimize performance loss and reduce downtime
  - Extension to distributed networked monitoring and fault-tolerant control

Applications and Industrial Collaboration

- Chemical process networks: benzene alkylation

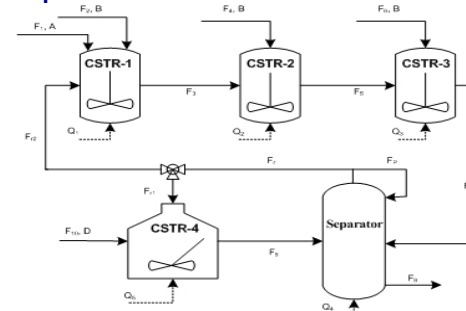

- Networks of water systems with renewable energy generation

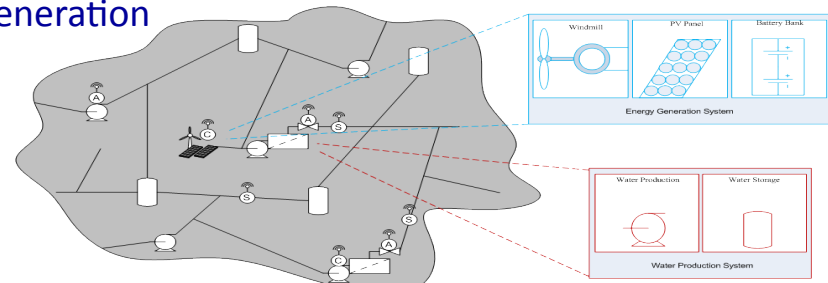

- Collaboration with ASM<sup>®</sup> consortium involving 15 major chemical and petrochemical companies

# Fundamental Advances in Control of Wireless Sensor and Robotic Networks

Chopra, Nikhil

NEXT:

Kuipers

Bretl

# FUNDAMENTAL ADVANCES IN CONTROL OF WIRELESS SENSOR AND ROBOTIC NETWORKS

Depending on the task at hand, a WSRN can possibly give rise to two basic communication architectures among the various nodes.

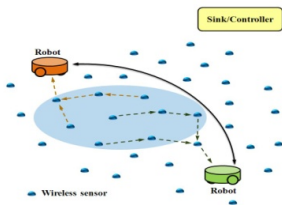

Automated architecture

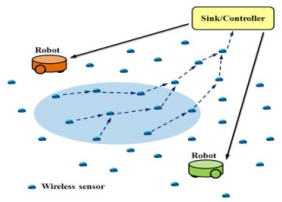

Semi-automated architecture

- Wireless Sensor and Robotic Networks (WSRN) are composed of interacting wireless sensors, robotic systems, and sink/central controllers communicating over a wireless network.
- The objective of the project is to investigate control algorithms for robotic systems based on the sensed data and study coordination strategies between the robots communicating over inherently unreliable wireless networks.
- Studies accomplished in the first year:
  - In the semi-automated architecture, passivity-based control was harnessed as fundamental tool to study control of robotic systems under time varying input/output delays.
  - In the automated architecture, control algorithms were developed to guarantee task space synchronization of distributed robots communicating under times delays.
  - A semi-passivity property for robotic systems was developed and exploited to study robustness to disturbances.

# Learning to Sense Robustly and Act Effectively

Kuipers, Benjamin

NEXT:

Bretl

Hassibi

# Learning to Sense Robustly and Act Effectively

Benjamin Kuipers, P.I. and Silvio Savarese, co-P.I.

University of Michigan, Ann Arbor, Michigan

To cope with a complex world, a CPS needs to learn *its own* knowledge of foundational domains:

- **Space:** Where things are; how to get there.
- **Objects:** What parts of the world have separate state?
- **Actions:** How can the agent affect the state of an object?

## Semantic Constraints in Vision

Joint inference formulation for estimating geometric and semantic properties of the scene from a single un-calibrated image

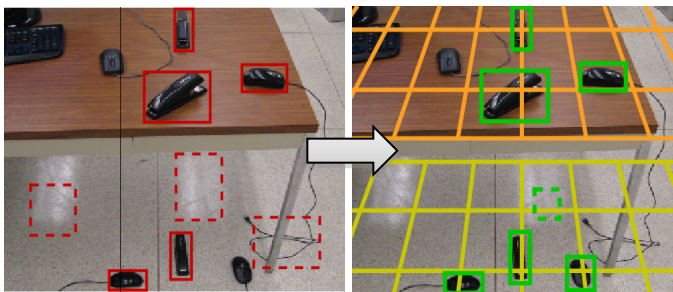

## Learning about Objects

- 2D2D: objects as regions in image
- 2D3D: planar faces with poses in 3D
- 3D3D: 3D object models in 3D

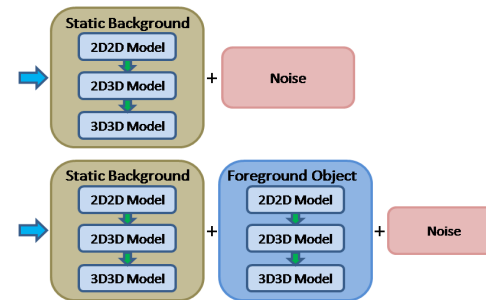

Robot autonomously learns a hierarchy of actions.

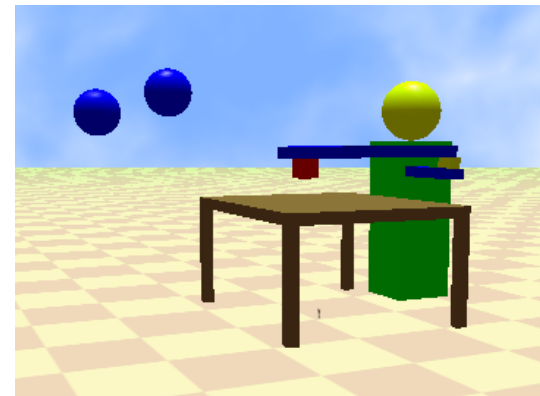



# Mathematical, Computational, and Perceptual Foundations for Interactive Cyber-Physical Systems

Bretl, Timothy

NEXT:

Hassibi

Bekris

# Mathematical, Computational, and Perceptual Foundations for Interactive Cyber-Physical Systems

Tim Bretl (PI) and Seth Hutchinson (co-PI), University of Illinois at Urbana-Champaign

## Goal:

- ▶ Create interfaces that enable people with impaired sensory-motor function to control interactive cyber-physical systems such as artificial limbs, wheelchairs, automobiles, and aircraft

## Key Idea:

- ▶ Enhance performance merely by changing the **perceptual feedback** given to the human user

## Approach:

- ▶ Encode local performance criteria (e.g., stability and collision avoidance) by potential functions, and use gradients of these functions to modify feedback
- ▶ Encode global performance criteria (e.g., optimal navigation) by conditional probabilities on a language of motion primitives, and use metric embeddings of these probabilities to modify feedback

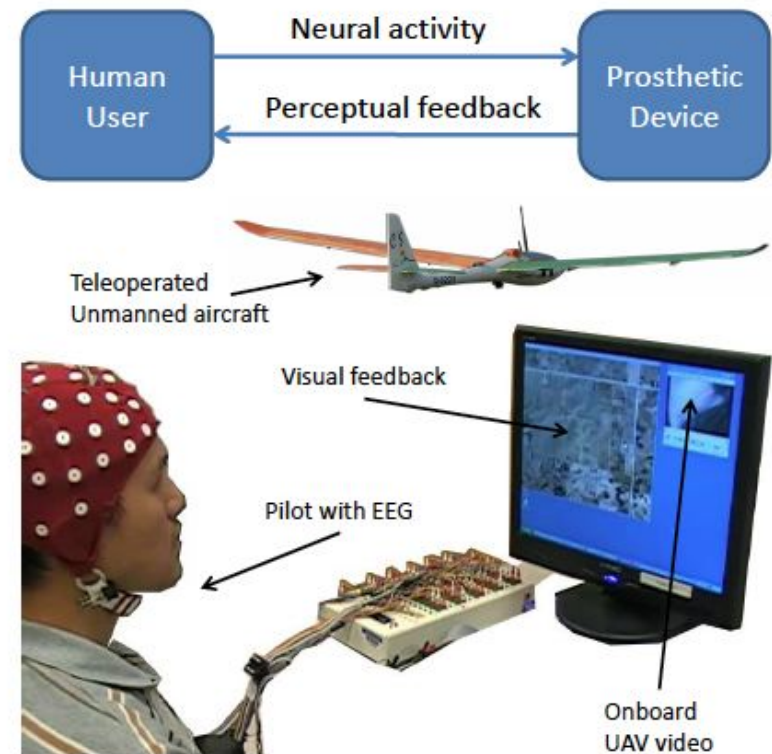

**Example:** By careful choice of visual feedback, we have enabled a human pilot to fly an unmanned aircraft with input only from an electroencephalograph (EEG)

# Random Matrix Recursions and Estimation and Control over Lossy Networks

Hassibi, Babak

NEXT:

Bekris

Sartipi

- **Motivation**

- estimation and control over lossy networks figures prominently in many cyber-physical systems
- central to the study of such systems is the behavior of *random* Lyapunov and Riccati recursions

- **Challenge**

- tools for analyzing such systems are woefully lacking---ostensibly because the recursions are both nonlinear and random, and hence intractable to analyze exactly

- **Approach: Large Random Matrix Theory**

- a *high-dimensional matrix-valued nonlinear and stochastic* recursion is replaced by a *scalar-valued deterministic functional* recursion (involving a suitable transform of the eigendistribution)

- **Benefits**

- stability analysis, cost analysis (average and worst-case), *universal behavior* exhibited

# Real-time, Simulation-based Planning and Asynchronous Coordination for Cyber-Physical Systems

Bekris, Kostas

NEXT:

Sartipi

Ozguner



# CPS: Small: Real-time, Simulation-based Planning and Asynchronous Coordination for Cyber-Physical Systems

## 1. How to plan without explicit mathematical models?

*Study simulation-based planning.*

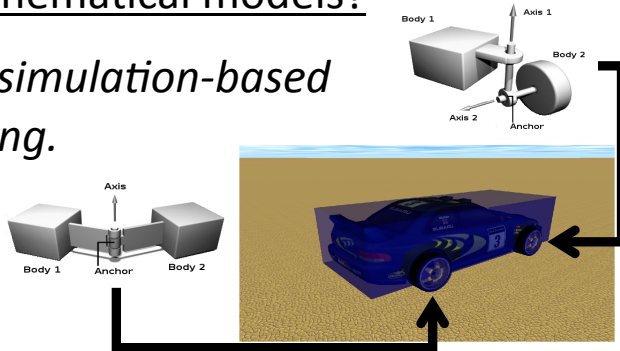

## 2. How to safely plan in real-time given a limited horizon?

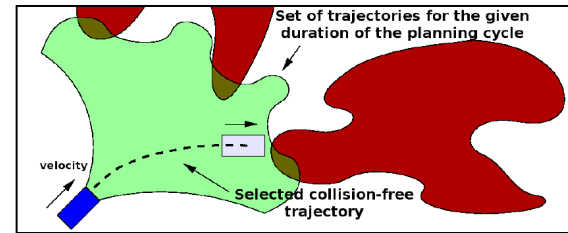

*Study safety guarantees.*

## 3. How to safely coordinate agents in an asynchronous manner?

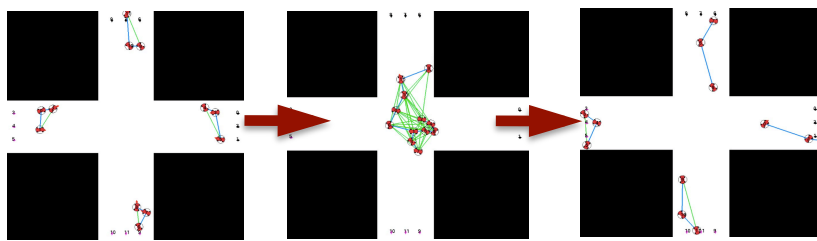

*Study asynchronous coordination.*

## 4. How to coordinate over a network given local, partial knowledge?

*Study network guided navigation of multiple agents (e.g., vehicles in an urban setup).*

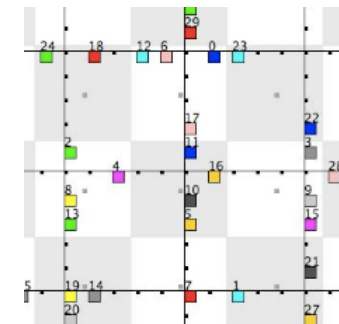

Inspiration Motion Planning and Distributed Optimization  
Applications Beyond Robotics: Manufacturing and Transportation





# RUI: CPS Foundations in Computation and Communication

Sartipi, Mina

NEXT:

Ozguner

Agogino

# “CPS Foundations in Computation and Communication”

Small: RUI – Mina Sartipi (PI) & Stephen Craven (Co-PI)

University of Tennessee at Chattanooga

*Summary* – Novel computation and communication schemes are being developed to reduce energy consumption and improve timing predictions.

## Computation

*Problem* – Modern processor architectures complicate timing analysis. Real-time scheduling improves with accuracy of code execution time estimates.

*Approach* – Instructions from different threads interleaved in pipeline. Data hazards removed, eliminating branch prediction, pipeline stalls, etc., creating a Precision Timed (PRET)  $\mu$ P.

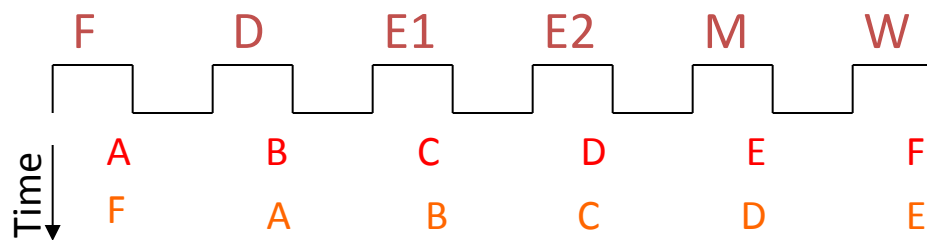

*Results* – 6-stage pipeline eliminates hazards and multi-cycle instructions. FPGA implementation yields 2x speed-up over conventional processor with minimal area increase.

## Communication

*Problem* – A simple, energy-efficient, and reliable communication scheme is required for relaying information between CPS nodes in CPS networks.

*Approach* – Combine the best of multicasting with the best of distributed source coding (DSC) which incorporates and uses ideas from rateless coding. Using the reliable TCP multicasting channel to deliver data through common links and build up multiple multicasting paths. The construction of multiple paths maximizes throughput of common paths while minimizing the total cost of each path.

*Results* – The introduced multicast algorithm outperforms the existing algorithms over lossy channels in terms of total number of required transmissions per transmitted packet.

# Autonomous Driving in Mixed-Traffic Urban Environments

Ozguner, Umit

NEXT:

Agogino

Pattipati

# Autonomous Driving in Urban Environments

*“Autonomous vehicles operating safely in mixed-traffic urban environments”*

- Collaborative Driving:
  - Convoying,
  - GCDC 2011.
- Hybrid-State Systems:
  - DES-CES Interaction,
  - DGC 2004 & 2005, DUC 2007, MAGIC 2010, GCDC 2011,...
- Estimation and Tracking in Complex, Mobile Environments
  - Stochastic nature of the controller/vehicle interaction.
  - HMM formulations and data collection.
- Computational Aspects
- Correctness of Software
- Vehicles, Simulator and Testbed



August 10, NSF CPS PI Meeting - Arlington, VA

# Collaborative Research: Distributed Coordination of Agents for Air Traffic Flow Management

Agogino, Adrian; Tumer, Kagan

NEXT:

Pattipati

Chen

# CPS Small: Distributed Coordination of Agents For Air Traffic Flow Management

PIs: Kagan Tumer (Oregon State University); Adrian Agogino (UC, Santa Cruz)

- **Problem:**
  - Inefficiencies in air traffic control cost time and money (\$41 Billion in 2007)
  - Most approaches are hard to scale and cannot handle dynamic/noisy situations
  - Local congestion management may causes propagation of congestion
  - Global congestion management slow to react to developing conditions
- **Opportunity:**
  - Multiagent approach offers to speed up response by focusing on local response
  - New problem: How to measure global impact of local decisions?  
What about congestion propagation?
- **Objectives:**
  1. Derive a fast simulator to compute system states and agent rewards
  2. Select agent actions and rewards and evaluate their system-wide impact
  3. Show effectiveness of agent actions/rewards with real air traffic data
- **Scientific Approach/Merit:**
  - Select agents, actions and rewards to have “alignment” within system
  - Shift focus from “how to learn/control” to “what to learn/control”
- **Impact:**
  - Coordinated behavior for thousands of agents w/o external mechanisms
  - Potential savings of billions of dollars and millions of traveler hours

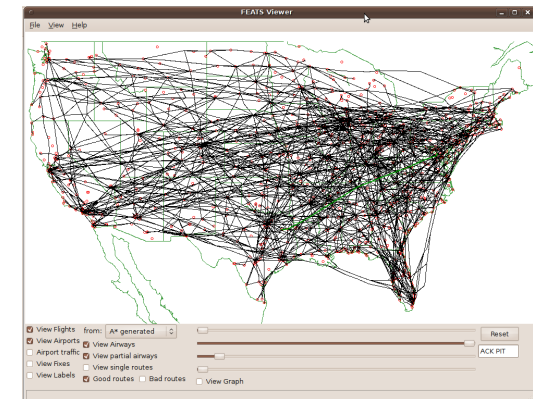
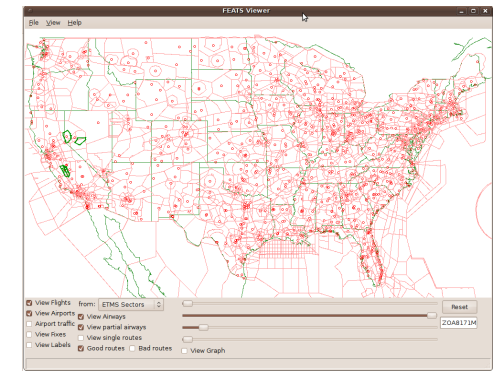
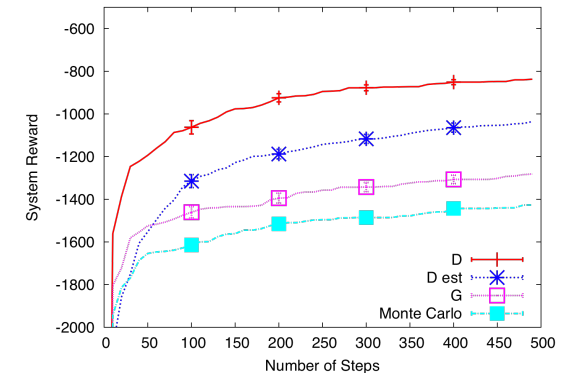

# Collaborative Research: Fault Diagnosis and Prognosis in a Network of Embedded Systems in Automotive Vehicles

Pattipati, Krishna; Gokhale, Swapna;  
Howell, Mark; Zhang, Yilu

NEXT:

Chen

Goddard





# CPS Small: Fault Diagnosis and Prognosis in a Network of Embedded Systems in Automotive Vehicles

NSF Grant: 0931956

PI: Krishna R. Pattipati<sup>1</sup> Co-PI's: Bing Wang<sup>2</sup>, Swapna Gokhale<sup>2</sup>, Yilu Zhang<sup>3</sup>, Mark Howell<sup>3</sup>, Mutasim A. Salman<sup>3</sup>

Student Contributors: Chaitanya Sankavaram<sup>1</sup>, Anuradha Kodali<sup>1</sup>, Bharath Pattipati<sup>1</sup>

<sup>1</sup>Dept. of Electrical and Computer Engineering, <sup>2</sup>Dept. of Computer Science Engineering, University of Connecticut, Storrs, CT 06269; <sup>3</sup>GM Research Center, General Motors Corporation, Warren, MI 48090

## ■ Research Objectives

- Diagnosis of physical system, electronic control unit and network faults
- Fault prognosis to predict the remaining useful life (RUL) of physical components based on the inferred failing components and their tracked paths of degradation

## ■ Technical Approach

- Dependency model generation for failure modes, effects and criticality analysis and test point optimization (Simulink/PSAT + CANoe )
- Coupled factorial hidden Markov models + Lagrangian relaxation/Gauss-Seidel + Viterbi for online inference of *multiple, coupled and intermittent* faults
  - Dynamic multiple fault diagnosis (DMFD) with *delayed* observations
  - Dynamic coupled fault diagnosis
  - Dynamic fusion of classifiers
  - Dynamic set covering
- Prognosis in *coupled* systems based on failure time, parametric and dynamic signal data
  - Survival functions of test outcomes via Cox proportional hazards model
  - Infer component survival functions via *soft* DMFD and estimate RUL

## ■ Target System: Regenerative Braking in Hybrid Electric Vehicles

### ■ Benefits

- Reduced mean time to repair
- Improved customer satisfaction
- Increased vehicle availability
- Reduced cost of service and warranty costs





# Infusing System Design and Sensor Technology in Education (INSIGHT)

Neilsen, Mitchell

NEXT:

Griswold

Bayen

# Infusing System Design and Sensor Technology in Education (INSIGHT)

– A GK-12 Graduate STEM Fellowship Program at Kansas State University

NSF-DGE 0948019, M. Neilsen, G. Singh, J. Spears, V. Wallentine, N. Zhang, [gk12.cis.ksu.edu](mailto:gk12.cis.ksu.edu)

INSIGHT GK-12 themes are important to rural Kansas

- Precision Agriculture



- Cyber-Health

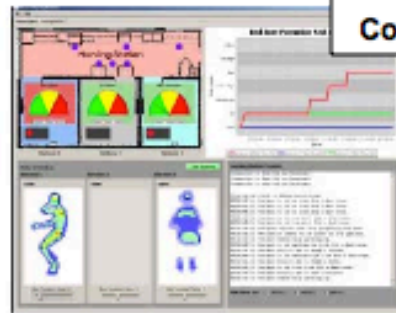

Data Collection

Reports & Prescriptions

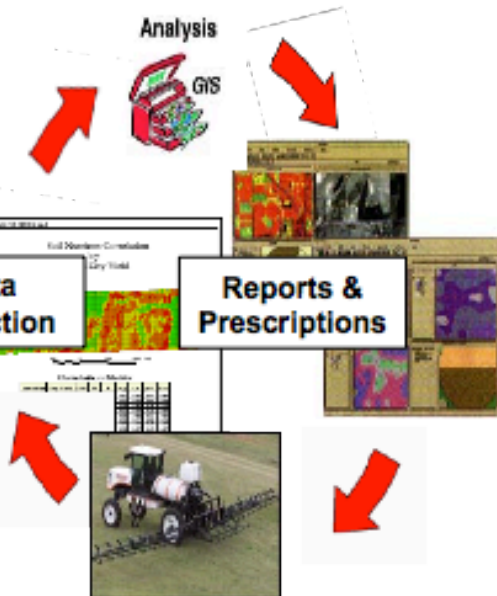

## Focus Areas:

- Rural Kansas Schools – Physical and Vocational Education
- STEM focus – Technology and Engineering
- Leverage Strengths – real-time embedded systems, software engineering, model checking, security, precision agriculture, wireless sensor networks



# CitiSense - Adaptive Services for Community-Driven Behavioral and Environmental Monitoring to Induce Change

Griswold, William

NEXT:

Bayen

Chamberlain

# CitiSense - Adaptive Services for Community-Driven Behavioral and Environmental Monitoring to Induce Change

William Griswold (PI)  
Piero Zappi

Ingolf Krüger  
Nichole Quick\*

Kevin Patrick\*  
Celal Ziftci

Tajana Šimunić Rosing  
Caleb Crawford

Nakul Verma

Sanjoy Dasgupta  
Nima Nikzad

Hovav Shacham  
Priti Aghera

UC San Diego

## Motivation & Concept

- Air pollution is a pervasive problem
- Environment is under-instrumented
- Idea
  - Continuously monitor with wearable and environmental sensors
  - Aggregate data for analysis,
  - Reflect results back to populace
- Considerable Challenges

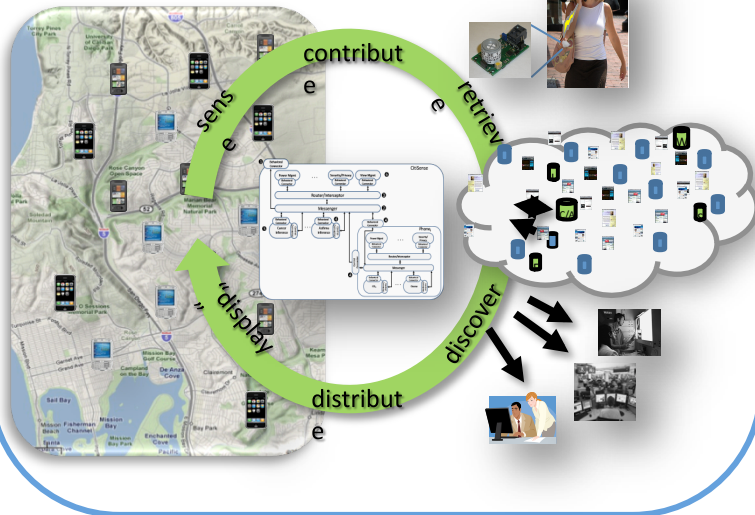

## System Architecture

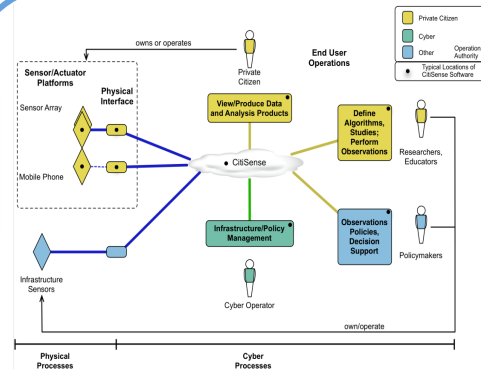

## Energy Management

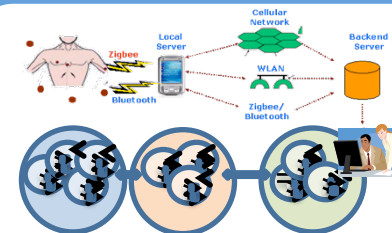

## Security & Privacy

(Supply secret key to read)

## Progress & Next Steps



- Algorithms
- Sensor-node implementation
- User studies

## Rich Services Service-Oriented Architecture

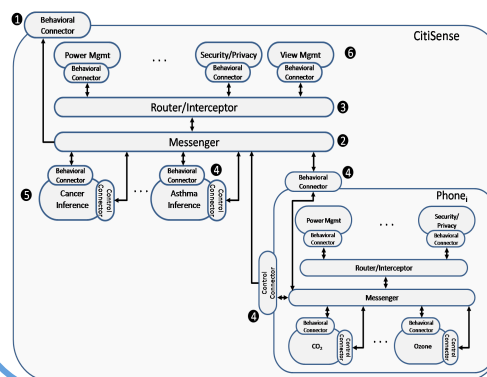

# Collaborative Research: Physical Modeling and Software Synthesis for Self-Reconfigurable Sensors in River Environments

Bayen, Alexandre; Sprinkle, Jonathan;  
Martinez, Sonia

NEXT:

Chamberlain

*Not Applicable*



# Physical modeling and software synthesis for self-reconfigurable sensors in river environments

S. Martinez, A. Kwok, A. Bayen, A. Tinka, J. Sprinkle, H. Al-Helal

- **The application: management of tidally forced rivers – a source of drinking water for millions of Americans, important to keep clean**
- This project integrates:
  - **Algorithm development** for the **motion control** and dynamic **deployment** of mobile semi-passive sensors in river environments
  - **Modeling techniques and assimilation of data** generated by passive and semi-passive drifters
  - **Software tools** for design, verification, and **code synthesis** for implementation.
- The approach:
  - Dynamic sensors, capable of motion relative to a flowing medium, but not “more powerful” than the medium itself
  - Distributed control for coverage of the fast-flowing environment
  - Quadratic programming to assimilate data from moving sensors using shallow water equations
  - Model-based techniques to automate software synthesis for embedded controllers
  - Prototype development and in-field testing of drogues

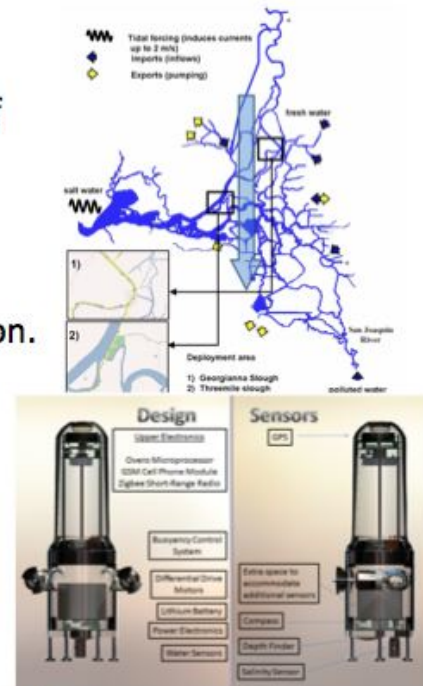

# Low-Impact Monitoring of Streaming Systems

Chamberlain, Roger

NEXT:

*Not Applicable*

*Not Applicable*

# Low-Impact Monitoring of Streaming Systems

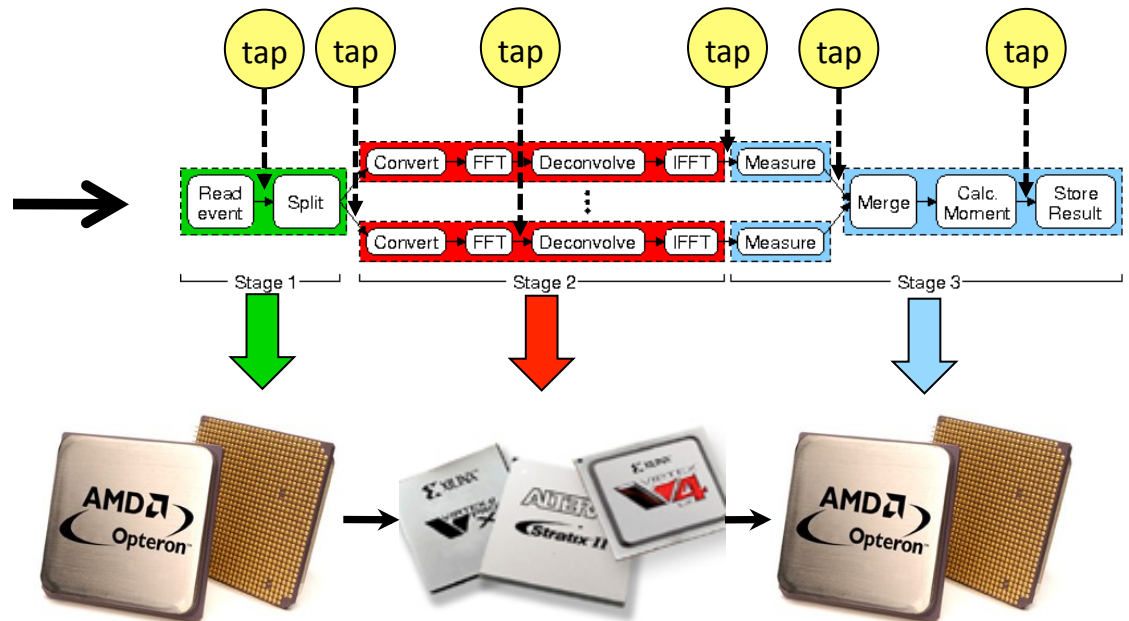
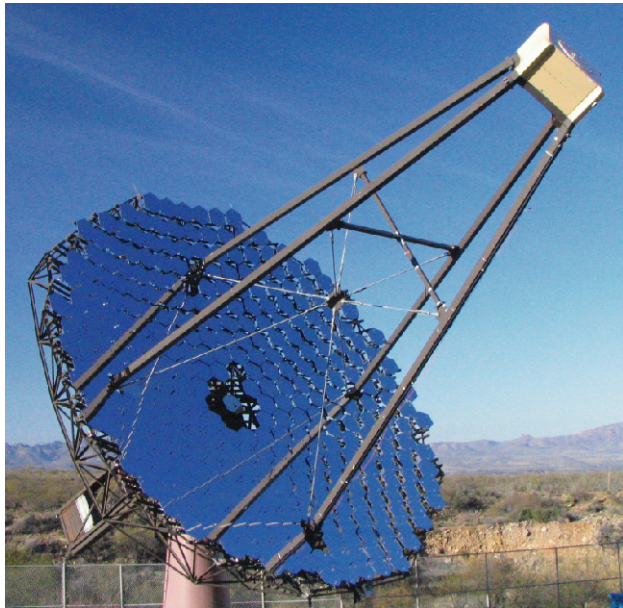

Where is the performance bottleneck?

How do we monitor without perturbing the execution?

